

HOKE® & GYROLOK®

Installation Manual for Tube & Precision Instrument Pipe Fittings



CRANE

CRANE Instrumentation & Sampling, HOKE®
PO Box 4866 • Spartanburg, SC 29305-4866
(864) 574-7966 • www.hoke.com

Table of Contents

Tube Fitting		HOKE® Safety Check List	57
Identification Guide	2	Safety Warning	58
About HOKE®...	1	How To Order	59
<i>Table of Contents</i>	1	GYROLOK® Fittings-Dimensional & Application Tables	61
Pipe	4	O-Rings Installation	
Pipe Threads	5	Instructions	65
<i>Straight Threads</i>	5	Male Connectors	67
<i>Taper Threads</i>	5	SAE Connectors	74
Applying Thread Tape	6	Female Connectors	77
The Pipe vs. Tubing Decision	7	Unions	84
The Advantages of Tubing	8	AN Fittings	91
Tubing Variables	9	Butt Welds	95
Tubing Data Charts	12	Thermocouple Connectors	105
Temperature Derating	38	Heat Exchanger Tees	107
Care and Handling of Tubing	39	Adapters	109
Bending the Tubing	41	Ferrules	117
Bending Information Charts	42	Calibration Fittings	120
GYROLOK® Assembly Instructions	49	Dielectric Fittings	122
<i>Remake Instructions</i>	51	HOKE® Chromatography Fittings	125
Installation Aids	52		

Tube Fitting Identification Guide



Connector, Male:
CM



Connector, Female:
CF



Union:
U



Reducing Union:
RU



Bulkhead Connector
Male: **BCM**



Bulkhead Connector,
Female: **BCF**



Bulkhead Union:
BU



Bulkhead Adapter:
BA



Elbow, Male:
LM



Elbow, Female:
LF



Elbow, Union:
LU



Male Branch Tee:
TMT



Male Run Tee:
TMT



Female Branch Tee:
TTF



Female Run Tee:
TFT



Union Tee:
TTT



Union Cross:
C



Reducer:
R



Cap:
CP



Plug:
P



Adapter, Male:
AM



Adapter, Female:
AF



Connector, O-ring
Straight: **COS**



Adapter, O-ring
Straight: **AOS**



Connector, Butt Weld:
CBW



Elbow, Butt Weld:
LBW



Connector, Socket Weld:
CW



Elbow, Socket Weld:
LW



Tube Insert:
TI



Port Connector:
PC



Nut:
N



Ferrule, Rear:
FR



Ferrule, Front:
FF



Nut and Ferrule Safety Changer:
SCNF



Ferrule Safety Changer:
SCF

About this manual...

Many tube and pipe fittings are designed to safely handle high pressures and temperatures, with hazardous or poisonous fluids, and to do so simply and safely.

Proper performance, however, demands correct assembly and installation.

Not only must the fitting product be used correctly but the mating product, meaning tube or pipe, must be selected, handled, and prepared in a manner to ensure maximum fitting performance.

This manual will:

1. Help assure maximum user awareness of key installation procedures and considerations.
2. Familiarize the user with pipe and pipe fittings, including their key characteristics, assembly procedures, and usage precautions.
3. Compare pipe and tube.
4. Review key tubing installation practices including: selection, cutting, deburring, and bending.
5. Familiarize the user with tube fittings, in general, including their key characteristics, important differences between manufacturers, various assembly procedures, and usage precautions.

Keep this manual readily available. You'll find it to be a handy reference tool.

Pipe



Pipe, by definition, is a hollow, elongated metallic structure used to convey fluids. The same definition, in fact, applies to tube.

Pipe sizes, however, are not what might be expected. For example, 1/4" nominal bore (NB) pipe has an outside diameter of 0.540". 1/2" pipe has an actual outside diameter of 0.840". Wall thicknesses, expressed by a schedule number, may vary. The greater the wall thickness, the higher the schedule number and the higher the pressure rating of the pipe.

PIPE SIZE	ACTUAL OUTSIDE DIAMETER
1/8" NB	0.405"/10.3 mm
1/4" NB	0.540"/13.7 mm
3/8" NB	0.675"/17.1 mm
1/2" NB	0.840"/21.3 mm
3/4" NB	1.050"/26.7 mm
1" NB	1.315"/33.4 mm

Pipe Threads

The most common method of joining pipe is with threads. Although there are many pipe thread specifications, there are in general only two primary types; straight and taper. NPT threads found on GYROLOK[®] tube fittings exceed the requirements of ANSI B1.2.1. This results in more consistent assembly and minimized thread galling.

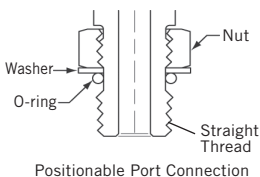
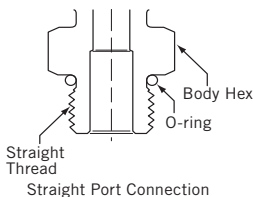
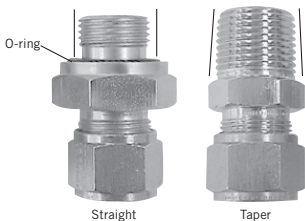

Straight Threads

When joining pipe or tube there are two functions to be accomplished: joining and sealing. Straight threads are used for joining, only. Sealing is accomplished by means of a gasket or O-ring.

The Society of Automotive Engineers (SAE) has developed specifications for specific straight thread and O-ring combinations. Shown to the left are two drawings. The top one is of an SAE straight port connection. The bottom is of an adjustable or positionable one.

The positionable port utilizes a separate nut and washer to be tightened against the O-ring for sealing. It is important to ensure that the nut is sufficiently backed off prior to installation to prevent pinching the O-ring, which could result in a leaking connection.

Taper Threads

Taper threads such as NPT, which stands for National Pipe Taper, are intended to provide a seal but must be used with a thread tape or liquid sealant to do so. No separate o-ring or gasket is needed.

Caution: O-rings, gaskets, thread tapes, and liquid sealants must each be considered for media compatibility as well as temperature rating.

Thread Tape

Thread tape acts as a lubricant allowing more thread engagement, preventing galling, and filling the gap between the crests and roots of mating taper threads in order to prevent formation of a spiral leak path.

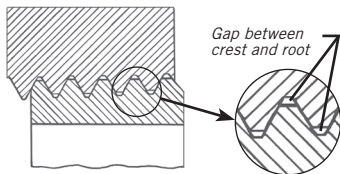

Two popular thread lubricants are TFE tape and liquid or dispersant sealants containing TFE. TFE tape should comply with a recognized standard such as MIL-T-27730. Tape typically has a temperature limitation of 450° F/230° C. For higher temperature applications consider the use of a nickel-additive thread sealing tape or a high temperature lubricant.

Applying Thread Tape



Always apply TFE tape to the male taper threaded end. Wrap the tape in the direction of the thread. All standard HOKE® NPT threads are right-handed meaning the tape must be applied in a clockwise direction.

Draw the tape tightly around the thread, ensuring, at a minimum, one complete wrap of the tape, ($1\frac{1}{4}$ turns is recommended) overlapping slightly.

Be sure the tape does not overhang the first thread otherwise the tape could deteriorate and contaminate the fluid system. On stainless steel a double wrap is recommended to minimize any possible galling, while providing a good seal. As shown in the chart above, also ensure that the appropriate minimum number of threads have been wrapped.

NOMINAL PIPE SIZE	TAPE WIDTH	EFFECTIVE THREAD LENGTH (EXTERNAL)	APPROX. # OF THREADS
$\frac{1}{8}$ "	$\frac{1}{8}$ – $\frac{1}{4}$ "	$\frac{1}{4}$ "	7
$\frac{1}{4}$ "	$\frac{1}{4}$ "	$\frac{3}{8}$ "	$7\frac{1}{3}$
$\frac{3}{8}$ "	$\frac{1}{4}$ "	$\frac{3}{8}$ "	$7\frac{1}{2}$
$\frac{1}{2}$ "	$\frac{1}{4}$ – $\frac{1}{2}$ "	$\frac{1}{2}$ "	$7\frac{1}{2}$
$\frac{3}{4}$ "	$\frac{1}{4}$ – $\frac{1}{2}$ "	$\frac{9}{16}$ "	$7\frac{2}{3}$
1"	$\frac{1}{4}$ – $\frac{1}{2}$ "	$\frac{11}{16}$ "	8



Press tape firmly into threads, particularly in the overlap area. The taped thread is then ready to assemble to a female thread.

Caution: Consider using gloves to press tape into threads that are: old, sharp, etc.

The Pipe vs. Tubing Decision

For a long period of time, threaded pipe was the most common method of joining and sealing most fluid line systems. Even today pipe continues to offer several benefits.

The advantages of threaded pipe are:

1. Simplicity.
2. Consistent assembly.
3. Lower fitting cost.

The fact is, however, that pipe involves many hidden costs.

Pipe's disadvantages are:

1. Lower strength to weight ratio—in order to accommodate threads, added size and weight are required.
2. Higher material cost of pipe—added weight means added material and added cost.
3. Pipe is not easily bendable—except for certain specific situations, a direction change requires a fitting.
4. Sharp bends or corners cause greater pressure drops.
5. Pipe is typically prepared and joined with NPT threads that require the use of a thread tape or lubricant. TFE tape has a lower temperature rating than stainless steel. Tape suitability must be considered for the application.
6. Size identification is difficult—recognition requires experience.

Tubing



Today, tubing is more cost effective and more commonly used than pipe.

Tubing, like pipe, is a hollow elongated metal structure. Unlike pipe, however, it is easily identifiable. Tube size

is designated by its outside diameter. $\frac{1}{4}$ " tube actually has an outside diameter of $\frac{1}{4}$ ". Various wall thicknesses are available which change the inside diameter, but not the outside diameter.

Tubing is typically joined through the use of tube fittings which are also responsible for providing leak-tight sealing. No special tubing preparation for a tube fitting connection is required, other than a squarely cut, deburred end. Note that tube fittings which incorporate a taper thread end will require a tape or thread lubricant on the taper thread end.

The Advantages of Tubing:

1. Easy Size Identification

- Saves time and money

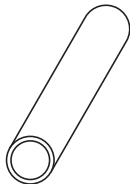

$\frac{1}{4}$ " Pipe = 0.540" O.D.



$\frac{1}{4}$ " Tube = 0.250" O.D.

2. Tubing has a higher strength to weight ratio because it doesn't require extra wall thickness to accommodate threads.

- Reduces material cost

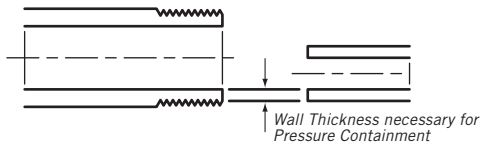

3. Bendability

- Reduces connections and possible leak paths
- Reduces time, labor, and material costs
- Lowers pressure drops

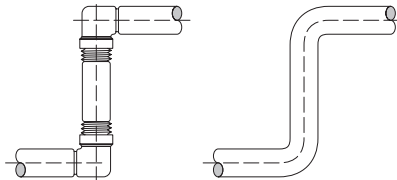

4. Tubing Simplifies Maintenance

- Tubing and tube fittings are more easily disassembled and reassembled since fewer connections are involved



5. Tubing Does Not Require Thread Tape/Lubricant

- Reduces installation time
- Assures maximum system temperature rating
- Ensures a cleaner system



Tubing Variables

A number of variables must be considered in the selection of tubing suitable for use with tube fittings. Key considerations include: materials of construction and applicable specification, welded or seamless construction, tubing hardness, tubing concentricity and roundness, and tubing wall thickness.

1. Materials

HOKE® manufactures its GYROLOK® Tube Fittings are manufactured for use with a variety of tubing materials which comply with recognized standards (or equivalents) including the following:

TUBING MATERIAL	UNS NUMBER	SPECIFICATION
Copper	C12200	ASTM B-75
304 stainless steel (seamless)	S30400	ASTM A-213
304 stainless steel (welded)	S30400	ASTM A-249
316 stainless steel (seamless)	S31600	ASTM A-213
316 stainless steel (welded)	S31600	ASTM A-249
MONEL® 400	N04400	ASTM B-165
INCONEL® 600	N06600	ASTM B-167
HASTELLOY® C-276	N10276	ASTM B-622
Titanium	R50400	ASTM B-338
254 SMO alloy steel	S31254	ASTM A-269
2205 Duplex	S31803	ASTM A-789
2507 Super Duplex	S32750	ASTM A-789
INCONEL® 625	N06625	ASTM B-444
INCONEL® 825	N08825	ASTM B-423

Note: It is the user's responsibility to assure that the tubing selected is compatible with the process fluid, temperature, and environment.

2. Welded vs. Seamless Tubing

Tubing is typically manufactured in one of two primary types, welded or seamless. Welded tubing is formed by wrapping the heated metal around a mandrel, and bringing it close together, but leaving a small gap or seam. It is then welded along the seam. Seamless tubing is formed by drawing the metal over a precisely sized mandrel. There is no seam and therefore no weld. While properly manufactured welded tubing is suitable for use with tube fittings, HOKE® recommends the use of seamless tubing because of increased consistency of performance and a higher maximum allowable working pressure.

3. Tubing Hardness

Proper tube fitting performance demands that the ferrules of the fitting be significantly harder than the tubing on which it is used. Maximum allowable surface hardness for various tubing materials are listed below:

MATERIAL (FULLY ANNEALED)	UNS NUMBER	HARDNESS
Copper	C12200	65 15T
304 stainless steel	S30400	90 Rb
316 stainless steel	S31600	90 Rb
MONEL® 400	N04400	75 Rb
INCONEL® 600	N06600	88 Rb
HASTELLOY® C-276	N10276	98 Rb
Titanium	R50400	80 Rb
2205 Duplex	S31803	30 Rc
2507 Super Duplex	S32750	32 Rc
INCONEL® 625	N06625	25 Rc
INCONEL® 825	N08825	90 Rb
254 SMO Alloy Steel	S31254	96 Rb

Note: When using welded tubing, care must be taken that the weld bead is not excessively hard.

4. Tubing Concentricity and Roundness

Tubing ovality, or out-of-roundness, is a detriment to achieving a safe and proper installation.

The drawing to the right has been exaggerated to show how excessive ovality will prevent

balanced contact and penetration

by the ferrule. This situation will potentially lead to leakage and improper gripping. A poor bead on welded tubing may create the same effect as excessive ovality.

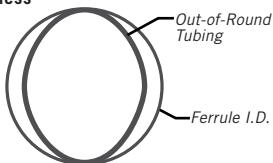

Leakage results when tubing is excessively oval.

Prevent Ovality

5. Tubing Wall Thickness

The wall thickness selection for any type of suitable tubing should be based on application pressure, temperature, and shock conditions. Note that **NOT** all tubing is suitable for use with tube fittings. 316 stainless steel and copper tubing suitable for use with GYROLOK[®] fittings are described on the following pages. The charts show the maximum allowable working pressure for a given wall thickness of that tubing when used at ambient temperatures. For additional materials, refer to HOKE's Tubing Data Charts brochure (79308). A critical consideration with welded tubing is the fact that its maximum allowable working pressure is less than that of seamless tubing, typically about 15%.

Tubing Data Charts

Copper Annealed Seamless Tubing

ASTM B-75 or Equivalent, Maximum Hardness HR_F 55

Maximum Working Pressure (bar) for Fractional Sizes

Allowable Stress = 6,000 psi between -20° F and 100° F

For Welded Tubing

For welded tubing, a derating factor must be applied for weld integrity.

- 1) For double-welded tubing, multiply working pressure by 0.85.
- 2) For single-welded tubing, multiply working pressure by 0.80.

Allowable working pressures are calculated based on equations from ASME B31.1 and ASME B31.3 for a maximum allowable stress (S) of 6,000 psi (41.3 MPa).

For gas service, select a wall thickness that is not shaded.

Copper Annealed Seamless Tubing

ASTM B-75 or Equivalent, Maximum Hardness HRf 55

TUBING O.D. (inch)	WALL THICKNESS (inch)														
	0.014	0.020	0.028	0.032	0.035	0.049	0.065	0.083	0.095	0.109	0.120	0.134	0.148	0.156	0.180
1/16	2800	4000													
1/8			2800	3300	3700										
3/16			1800	2100	2300	3400									
1/4			1300	1500	1600	2400	3400								
3/8				900	1000	1500	2100	2800							
1/2					700	1100	1500	2000							
5/8					600	800	1200	1500	1800						
3/4					500	700	900	1200	1500	1700					
7/8					400	600	800	1000	1200	1400					
1					300	500	700	900	1100	1200	1400				
1 1/4							500	700	800	1000	1100	1200	1300	1400	1700
1 1/2								400	700	800	900	1000	1100	1200	1400
2									300	600	600	700	800	800	1000

Ordering Information: High quality, fully annealed seamless tubing, ASTM B75 an EN 1057 or equivalent. Tubing to be free of scratches, and suitable for bending. Secondary mechanical finishing is prohibited.

Tubing Data Charts

Copper Annealed Seamless Tubing

ASTM B-75 or Equivalent, Maximum Hardness HR_F 55

Maximum Working Pressure (bar) for Metric Sizes

Allowable Stress = 41.3 MPa between -29° C and 38° C

For Welded Tubing

For welded tubing, a derating factor must be applied for weld integrity.

- 1) For double-welded tubing, multiply working pressure by 0.85.
- 2) For single-welded tubing, multiply working pressure by 0.80.

Allowable working pressures are calculated based on equations from ASME B31.1 and ASME B31.3 for a maximum allowable stress (S) of 6,000 psi (41.3 MPa).

For gas service, select a wall thickness that is not shaded.

Copper Annealed Seamless Tubing

ASTM B-75 or Equivalent, Maximum Hardness HRf 55

TUBING O.D. (mm)	WALL THICKNESS (mm)										
	0.8	1	1.5	2	2.5	3	4.0				
3	240										
4	170	220									
6	100	140	220								
8	80	100	160								
10	60	80	120	170							
12	50	60	100	140							
14		50	80	110	150						
15		50	80	100	140						
16		40	70	100	130	160					
18		40	60	80	110	140					
20		30	50	80	100	120					
22		30	50	70	90	110					
25		30	40	60	80	90					
28		20	40	50	70	80	110				
30				50	60	80	100				
32				40	60	70	100				
38					50	60	80				

Ordering Information: High quality, fully annealed seamless tubing, ASTM B75 an EN 1057 or equivalent. Tubing to be free of scratches, and suitable for bending. Secondary mechanical finishing is prohibited.

For gas service, select a wall thickness that is not shaded.

Tubing Data Charts

304 & 316 Stainless Steel Annealed Seamless Tubing

ASTM A-269 UNS S31600 or Equivalent, Maximum Hardness HR_B 90

Maximum Working Pressure (bar) for Fractional Sizes

Allowable Stress = 20,000 psi between -20° F and 100° F

For Welded Tubing

For welded tubing, a derating factor must be applied for weld integrity.

- 1) For double-welded tubing, multiply working pressure by 0.85.
- 2) For single-welded tubing, multiply working pressure by 0.80.

Allowable working pressures are calculated based on equations from ASME B31.1 and ASME B31.3 for a maximum allowable stress (S) of 20,000 psi (137.9 MPa). GYROLOK®-XP fittings are suitable for use with medium pressure (1/2-hard) seamless tubing with an allowable stress (S) of 35,000 psi (241 MPa). Values shown below are for seamless annealed tubing only.

For gas service, select a wall thickness that is not shaded. GYROLOK®-XP fittings are intended for use where pressures are indicated with the "XP" subscript. Tubing is suitable for use with either 316 stainless steel or 254 SMO GYROLOK® fittings.

304 & 316 Stainless Steel Annealed Seamless Tubing

ASTM A-269 UNS S31600 or Equivalent, Maximum Hardness HRB 90

TUBING O.D. (inch)	WALL THICKNESS (inch)																
	0.010	0.020	0.028	0.035	0.049	0.065	0.083	0.095	0.109	0.120	0.134	0.156	0.165	0.180	0.188	0.283	
1/16	5800	12600															
1/8			8900	11400													
3/16			5600	7300	10700												
1/4			4300	5600	8100	11100xp	14400xp	16300xp									
3/8				3600	5100	7100	9300xp	10800xp	12500xp	13900xp	15400xp						
1/2				2600	3700	5100	6700	7900xp	9200xp	10200xp	11500xp	13500xp	14300xp	15500xp	16200xp		
9/16																	
5/8					2900	4000	5200	6100									
3/4					2400	3300	4300	5000xp	5800xp	6500xp	7300xp	8700xp	9300xp				
7/8					2100	2800	3600	4200	4900								
1						2400	3100	3600	4200	4700	5300	6300					
1 1/4							2500	2800	3300xp	3700xp	4100xp	4900xp	5200xp				
1 1/2								2300	2700	3000	3400xp	4000xp	4300xp	4700xp	4900xp		
2									2000	2200	2500	2900xp	3100xp	3400xp	3600xp		

Ordering Information: High quality, fully annealed (Type 304, 304/304L, 316, 316/316L, 317, 317/317L) seamless tubing, ASTM A269 or equivalent. Tubing to be free of scratches, and suitable for bending. Secondary mechanical finishing is prohibited.

Tubing Data Charts

304 & 316 Stainless Steel Annealed Seamless Tubing

ASTM A-269 UNS S31600 or Equivalent, Maximum Hardness HR_B 90

Maximum Working Pressure (bar) for Metric Sizes

Allowable Stress = 137.9 MPa between -29° C and 38° C

For Welded Tubing

For welded tubing, a derating factor must be applied for weld integrity.

- 1) For double-welded tubing, multiply working pressure by 0.85.
- 2) For single-welded tubing, multiply working pressure by 0.80.

Allowable working pressures are calculated based on equations from ASME B31.1 and ASME B31.3 for a maximum allowable stress (S) of 20,000 psi (137.9 MPa). GYROLOK®-XP fittings are suitable for use with medium pressure (1/2-hard) seamless tubing with an allowable stress (S) of 35,000 psi (241 MPa). Values shown below are for seamless annealed tubing only.

For gas service, select a wall thickness that is not shaded. GYROLOK®-XP fittings are intended for use where pressures are indicated with the "XP" subscript. Tubing is suitable for use with either 316 stainless steel or 254 SMO GYROLOK® fittings.

304 & 316 Stainless Steel Annealed Seamless Tubing

ASTM A-269 UNS S31600 or Equivalent, Maximum Hardness HRB 90

TUBING O.D. (mm)	WALL THICKNESS (mm)														
	0.8	1	1.5	2	2.5	3	4.0								
3	710														
4		760													
6	360	470	730	990xp											
8		328	551												
10		260	410	570	730xp										
12		220	340	470	600xp										
14		169	283	400											
15		159	262	366											
16			240	340	430										
18			220	290	380	470xp									
20			190	260	340	410xp									
22			169	234	303										
25				210	260	320xp									
28				180	230xp	280xp									
30				170	220	260xp									
32				160	200	240xp	340xp								
38					170	200	280xp								

Ordering Information: High quality, fully annealed (Type 304, 304/304L, 316, 316/316L, 317, 317/317L) seamless tubing, ASTM A269 or equivalent. Tubing to be free of scratches, and suitable for bending. Secondary mechanical finishing is prohibited.

Tubing Data Charts

6MO

ASTM A-269 UNS S31254 or Equilavent, Maximum Hardness HR_B 90

Maximum Working Pressure (bar) for Fractional Sizes

Allowable Stress = 27,100 psi between -20° F and 100° F

For Welded Tubing

For welded tubing, a derating factor must be applied for weld integrity.

- 1) For double-welded tubing, multiply working pressure by 0.85.
- 2) For single-welded tubing, multiply working pressure by 0.80.

Allowable working pressures are calculated based on equations from ASME B31.1 and ASME B31.3 for a maximum allowable stress (S) of 27,100 psi (186.9 MPa).

For gas service, select a wall thickness that is not shaded. GYROLOK®-XP fittings are intended for use where pressures are indicated with the "XP" subscript. Tubing is suitable for use with either 316 stainless steel or 254 SMO GYROLOK® fittings.

6MO ASTM A-269 UNS S31254 or Equivalent, Maximum Hardness HR_B 90

TUBING O.D. (inch)	WALL THICKNESS (inch)									
	0.020	0.028	0.035	0.049	0.065	0.083	0.109	0.134		
1/4	3200	4900	6300	9300	15100xp					
3/8			4800	7000	9600xp	12600xp				
1/2			3500	5100	6900	9100xp	12400xp			
5/8				4000	5400	7100				
3/4				3300	4500	5800	7900xp			
7/8				2800	3800	4900				
1					3300	4300	5700xp	7200xp		
1 1/4							4500xp	5600xp		
1 1/2							3700xp	4600xp		

Ordering Information: High quality, fully annealed 6 MO tubing, ASTM A269 or equivalent. Tubing to be free of scratches, and suitable for bending. Secondary mechanical finishing is prohibited.

Tubing Data Charts

6MO

ASTM A-269 UNS S31254 or Equilavent, Maximum Hardness HR_B 90

Maximum Working Pressure (bar) for Metric Sizes

Allowable Stress = 186.9 MPa between -29° C and 38° C

For Welded Tubing

For welded tubing, a derating factor must be applied for weld integrity.

- 1) For double-welded tubing, multiply working pressure by 0.85.
- 2) For single-welded tubing, multiply working pressure by 0.80.

Allowable working pressures are calculated based on equations from ASME B31.1 and ASME B31.3 for a maximum allowable stress (S) of 186.9 MPa (27,100 psi).

For gas service, select a wall thickness that is not shaded. GYROLOK®-XP fittings are intended for use where pressures are indicated with the "XP" subscript. Tubing is suitable for use with either 316 stainless steel or 254 SMO GYROLOK® fittings.

6MO ASTM A-269 UNS S31254 or Equivalent, Maximum Hardness HR_B 90

TUBING O.D. (mm)	WALL THICKNESS (mm)							
	0.8	1	1.5	2	2.5	3	4	
3	1070	1350xp						
6	490	630	1000xp					
8		460	720xp					
10		360	560	780xp				
12		290	460	630xp				
14			390	530				
15			360	490				
16			330	460xp	590xp			
18			290	400xp	510xp			
20			260	360	460xp			
22			240	320	410xp			
25				280	360	440xp		
30				230xp	290xp	360xp		
38				180xp	230xp	280xp	380xp	

Ordering Information: High quality, fully annealed 6 MO tubing, ASTM A269 or equivalent. Tubing to be free of scratches, and suitable for bending. Secondary mechanical finishing is prohibited.

Tubing Data Charts

HASTELLOY® C-276 Solution Annealed Seamless Tubing ASTM B622 UNS N10276 or Equivalent, Maximum Hardness HRB 98

Maximum Working Pressure (psi) for Fractional Sizes

Allowable Stress = 27,300 psi between -20° F and 400° F

Allowable working pressures are calculated based on equations from ASME B31.3 and ASME B31.3 for a maximum allowable stress (S) of 27,300 psi (188.2 MPa).

TUBING O.D. (inch)	WALL THICKNESS (inch)							
	0.010	0.028	0.035	0.049	0.065	0.083	0.095	
1/16	8700							
1/8		13100	17200					
1/4		5900	7600	11200xp	15700xp			
3/8			4900	7000	9700xp			
1/2			3600	5100	7000			
3/4				4000	5500xp			
1					4500			
					3300	4300xp		5000xp

Ordering Information: High quality, fully annealed seamless alloy C-276 tubing, ASTM B622 or equivalent. Tubing to be free of scratches, and suitable for bending. Secondary mechanical finishing is prohibited.

HASTELLOY® C-276 Solution Annealed Seamless Tubing

ASTM B622 UNS N10276 or Equivalent, Maximum Hardness HR_B 98

Maximum Working Pressure (bar) for Metric Sizes

Allowable Stress = 188.2 MPa between -29° C and 204° C

Allowable working pressures are calculated based on equations from ASME B31.1 and ASME B31.3 for a maximum allowable stress (S) of 188.2 MPa (27,300 psi).

TUBING O.D. (mm)	WALL THICKNESS (mm)			
	1.0	1.5	2.0	2.5
3	890			
6	640xp	1030xp		
8	460	730xp		
10	360	560		
12	300	460		
18			400	
25			220	350

Ordering Information: High quality, fully annealed seamless alloy C-276 tubing, ASTM B622 or equivalent. Tubing to be free of scratches, and suitable for bending. Secondary mechanical finishing is prohibited.

GYROLOK®-XP fittings are intended for use where pressures are indicated with the "XP" subscript.

Tubing Data Charts

MONEL® 400 (Nickel-Copper) Annealed Seamless Tubing ASTM B-165 UNS N04400 or Equivalent, Maximum Hardness HRB 75

Maximum Working Pressure (psi) for Fractional Sizes

Allowable Stress = 18,700 psi between -20° F and 100° F

Allowable working pressures are calculated based on equations from ASME B31.1 and ASME B31.3 for a maximum allowable stress (S) of 18,700 psi (128.9 MPa)

TUBING O. D. (inch)	WALL THICKNESS (inch)			
	0.035	0.049	0.065	0.083
½	12100			
¼		7300	9900	
⅜		4500	6300	
½		3300	4600	6100
⅝			2700	
¾		2200	3000	
1			2200	

Ordering Information: High quality, fully annealed seamless alloy 400 hydraulic tubing, ASTM B165 or equivalent. Tubing to be free of scratches, and suitable for bending. Secondary mechanical finishing is prohibited.

GYROLOK®-XP fittings are intended for use where pressures are indicated with the "XP" subscript.

MONEL® 400 (Nickel-Copper) Annealed Seamless Tubing ASTM B-165 UNS N04400 or Equivalent, Maximum Hardness HR_B 75

Maximum Working Pressure (bar) for Metric Sizes

Allowable Stress = 128.9 MPa psi between -29° C and 38° C

Allowable working pressures are calculated based on equations from ASME B31.1 and ASME B31.3 for a maximum allowable stress (S) of 128.9 MPa (18,700 psi).

TUBING O.D. (mm)	WALL THICKNESS (mm)		
	1.0	1.5	2.0
3	890		2.5
6	550		
8	401		
10		497	
12		365	
18			370
25			220
			350

Ordering Information: High quality, fully annealed seamless alloy 400 hydraulic tubing, ASTM B165 or equivalent. Tubing to be free of scratches, and suitable for bending. Secondary mechanical finishing is prohibited.

GYROLOK®-XP fittings are intended for use where pressures are indicated with the "XP" subscript.

Tubing Data Charts

Grade 2 Titanium Annealed Seamless Tubing

ASTM B-338 UNS R50400 or Equivalent, Maximum Hardness HR_B 90

Maximum Working Pressure (psi) for Fractional Sizes

Allowable Stress = 16,700 psi between -20° F and 100° F

Allowable working pressures are calculated based on equations from ASME B31.1 and ASME B31.3 for a maximum allowable stress (S) of 16,700 psi (115.1 MPa). For working pressure in accordance with ASME B31.1 multiply by 0.85.

TUBING O.D. (inch)	WALL THICKNESS (inch)			
	0.028	0.035	0.049	0.065
1/8		10500		
1/4	3600	4600	6800	9600
3/8		3000	4300	5900
1/2		2200	3100	4300
3/4				2700
1				2000

Ordering Information: High quality, fully annealed seamless grade 2 titanium, ASTM B338 or equivalent. Tubing to be free of scratches, and suitable for bending. Secondary mechanical finishing is prohibited.

Grade 2 Titanium Annealed Seamless Tubing

ASTM B-338 UNS R50400 or Equivalent, Maximum Hardness HR_B 90

Maximum Working Pressure (bar) for Metric Sizes

Allowable Stress = 115.1 MPa between -29° C and 38° C

Allowable working pressures are calculated based on equations from ASME B31.1 and ASME B31.3 for a maximum allowable stress (S) of 115.1 MPa (16,700 psi). For working pressure in accordance with ASME B31.1 multiply by 0.85.

TUBING O.D. (mm)	WALL THICKNESS (mm)			
	1.0	1.5	2.0	2.5
6	390	610		
10	220	340	490	
12	180	280	390	
14			330	
16		210		
18		150	250	
20			220	280
25		130	170	220

Ordering Information: High quality, fully annealed seamless grade 2 titanium, ASTM B338 or equivalent. Tubing to be free of scratches, and suitable for bending. Secondary mechanical finishing is prohibited.

Tubing Data Charts

2507 Super Duplex Stainless Steel Solution Treated Seamless Tubing

ASTM A789 UNS S32750 or Equivalent, Maximum Hardness HRC 32

Maximum Working Pressure (psi) for Fractional Sizes

Allowable Stress = 36,300 psi between -20° F and 200° F

Allowable working pressures are calculated based on equations from ASME B31.1 and ASME B31.3 for a maximum allowable stress (S) of 36,300 psi (250.3 MPa).

TUBING O.D. (inch)	WALL THICKNESS (inch)				
	0.035	0.049	0.065	0.083	0.095
¼	10000xp	14800xp			
⅜	6500xp	9400xp	12900xp		
½	4800xp	6800xp	9300xp	12300xp	
⅝		5400xp	7300xp	9500xp	
¾		4400xp	6000xp	7800xp	
1			4400xp	5700xp	6600xp

For gas service, select a wall thickness that is not shaded.

Ordering Information: High quality, fully annealed seamless 2507 super duplex tubing, ASTM A789 or equivalent. Tubing to be free of scratches, and suitable for bending. Secondary mechanical finishing is prohibited.

2507 Super Duplex Stainless Steel Solution Treated Seamless Tubing

ASTM A789 UNS S32750 or Equivalent, Maximum Hardness HRc 32

Maximum Working Pressure (bar) for Metric Sizes

Allowable Stress = 250.3 MPa between -29° C and 93° C

Allowable working pressures are calculated based on equations from ASME B31.1 and ASME B31.3 for a maximum allowable stress (S) of 250.3 MPa (36,300 psi).

TUBING O.D. (mm)	WALL THICKNESS (mm)				
	1.0	1.5	2	2.5	3.0
6	850xp				
10	480xp	750xp			
12	390xp	610xp	850xp		
18		390xp	540xp		
20		350xp	490xp		
25		280xp	380xp	480xp	590xp

Ordering Information: High quality, fully annealed seamless 2507 super duplex tubing, ASTM A789 or equivalent. Tubing to be free of scratches, and suitable for bending. Secondary mechanical finishing is prohibited.

GYROLOK®-XP fittings are intended for use where pressures are indicated with the "XP" subscript.

Tubing Data Charts

INCONEL® 625 Nickel Alloy Seamless Tubing

ASTM B-444 UNS N06625 or Equivalent

Maximum Working Pressure (psi) for Fractional Sizes

Allowable Stress = 40,000 psi between -20° F and 200° F

Allowable working pressures are calculated based on equations from ASME B31.1 and ASME B31.3 for a maximum allowable stress (S) of 40,000 psi (275.8 MPa).

TUBING O.D. (inch)	WALL THICKNESS (inch)		
	0.035	0.049	0.065
¼	11200xp	16400xp	0.083
⅜	7200xp	10300xp	14200xp
½	5300xp	7500xp	10300xp
¾			6600xp
1			4900xp
			6300xp

Ordering Information: High quality, fully annealed seamless alloy 625 tubing, ASTM B444 or equivalent. Tubing to be free of scratches, and suitable for bending. Secondary mechanical finishing is prohibited.

GYROLOK®-XP fittings are intended for use where pressures are indicated with the "XP" subscript.

INCONEL® 625 Nickel Alloy Seamless Tubing ASTM B-444 UNS N06625 or Equivalent

Maximum Working Pressure (MPa) for Metric Sizes

Allowable Stress = 275.8 MPa between -28° C and 93° C

Allowable working pressures are calculated based on equations from ASME B31.1 and ASME B31.3 for a maximum allowable stress (S) 275.8 MPa (40,000 psi).

TUBING O.D. (mm)	WALL THICKNESS (mm)			
	1.0	1.5	2.0	2.5
6	940xp	1510xp		
10	530xp	830xp		
12	440xp	680xp	940xp	
18		440xp	590xp	
20		390xp	530xp	680xp

Ordering Information: High quality, fully annealed seamless alloy 625 tubing, ASTM B444 or equivalent. Tubing to be free of scratches, and suitable for bending. Secondary mechanical finishing is prohibited.

GYROLOK®-XP fittings are intended for use where pressures are indicated with the "XP" subscript.

Tubing Data Charts

INCONEL® 825 Nickel Alloy Seamless Tubing ASTM B-423 UNS N08825 or Equivalent

Maximum Working Pressure (psi) for Fractional Sizes

Allowable Stress = 23,300 psi between -20° F and 100° F

Allowable working pressures are calculated based on equations from ASME B31.1 and ASME B31.3 for a maximum allowable stress (S) of 23,300 psi (160.6 MPa).

TUBING O. D. (inch)	WALL THICKNESS (inch)				
	0.035	0.049	0.065	0.083	0.095
¼	6500	9500xp	13400xp		
⅜	4100	6000	8300xp		
½	3000	4400	6000	7900xp	
¾			3800	5000	5800xp
1			2800	3700	4200xp

Ordering Information: High quality, fully annealed seamless alloy 825 tubing, ASTM B423 or equivalent. Tubing to be free of scratches, and suitable for bending. Secondary mechanical finishing is prohibited.

GYROLOK®-XP fittings are intended for use where pressures are indicated with the "XP" subscript.

INCONEL® 825 Nickel Alloy Seamless Tubing

ASTM B-423 UNS N08825 or Equivalent

Maximum Working Pressure (bar) for Metric Sizes

Allowable Stress = 160.6 MPa between -29° C and 38° C

Allowable working pressures are calculated based on equations from ASME B31.1 and ASME B31.3 for a maximum allowable stress (S) of 160.6 MPa (23,300 psi).

TUBING O.D. (mm)	WALL THICKNESS (mm)			
	1.0	1.5	2.0	2.5
6	540	880xp		
10	310	480	670xp	
12	250	390	540xp	
18		250	340	440xp
20		220	310	390xp
25			240	310xp

Ordering Information: High quality, fully annealed seamless alloy 825 tubing, ASTM B423 or equivalent. Tubing to be free of scratches, and suitable for bending. Secondary mechanical finishing is prohibited.

GYROLOK®-XP fittings are intended for use where pressures are indicated with the "XP" subscript.

Tubing Data Charts

2205 Duplex Stainless Steel Solution Treated Seamless Tubing

ASTM A-789 UNS S31803 or Equivalent, Maximum Recommended Hardness HRC 30.5

Maximum Working Pressure (psi) for Fractional Sizes

Allowable Stress = 30,000 psi between -20° F and 200° F

Allowable working pressures are calculated based on equations from ASME B31.1 and ASME B31.3 for a maximum allowable stress (S) of 30,000 psi (206.8 MPa). For working pressure in accordance with ASME B31.1 multiply by 0.85.

TUBING O. D. (inch)	WALL THICKNESS (inch)					
	0.020	0.028	0.035	0.049	0.065	0.083
¼	4500	6500	8400xp			
⅜		4200	5400	7700xp	10700xp	
½		3100	3900	5600	7700	10100xp
¾			2600	3700	4900	6400xp
1					3600	4700xp

Ordering Information: High quality, fully annealed seamless alloy 825 tubing, ASTM B423 or equivalent. Tubing to be free of scratches, and suitable for bending. Secondary mechanical finishing is prohibited.

GYROLOK®-XP fittings are intended for use where pressures are indicated with the "XP" subscript.

2205 Duplex Stainless Steel Solution Treated Seamless Tubing

ASTM B-789 UNS S31803 or Equivalent, Maximum Recommended Hardness HRC 30.5

Maximum Working Pressure (bar) for Metric Sizes

Allowable Stress = 206.8 MPa psi between -29° C and 93° C

Allowable working pressures are calculated based on equations from ASME B31.1 and ASME B31.3 for a maximum allowable stress (S) of 206.8 MPa (30,000 psi). For working pressure in accordance with ASME B31.1 multiply by 0.85.

TUBING O.D. (mm)	WALL THICKNESS (mm)	
	1.0	2.0
10	400	620xp
12	330	510xp
14	280	430
15	260	400
16	240	370
18	210	330
25		240
		310

Ordering Information: High quality, fully annealed seamless 2205 duplex tubing, ASTM A789 or equivalent. Tubing to be free of scratches, and suitable for bending. Secondary mechanical finishing is prohibited.

GYROLOK®-XP fittings are intended for use where pressures are indicated with the "XP" subscript.

Temperature Derating

As application temperature increases maximum allowable working pressure decreases. The following chart provides derating factors for copper and 316 stainless steel tubing. To use, locate the maximum allowable working pressure for specific tubing in the tubing data charts. Multiply that number by the number in the chart below applicable to the application temperature.

Example: Determine the maximum allowable working pressure for 12mm 316 stainless steel annealed seamless tubing with a wall thickness of 1.5mm when used at 427° C.

Maximum allowable working pressure at ambient temperature
(from tubing data charts) = 324 bar

Derating factor for 427° C = 0.84

Maximum allowable working pressure
at 427° C = 324 bar × 0.84 = 272 bar

TEMPERATURES		COPPER	TYPE 316	
°F	°C	SEAMLESS ANNEALED TUBING SPEC. ASTM B-75	SEAMLESS ANNEALED TUBING SPEC. ASTM A-213	WELDED ANNEALED TUBING SPEC. ASTM A-249
		-20 to 100	-29 to 38	1.00
150	66	0.85	1.00	1.00
200	93	0.80	1.00	1.00
300	149	0.78	0.98	0.98
400	204	0.50	0.96	0.96
500	260	—	0.96	0.96
600	316	—	0.90	0.90
700	371	—	0.87	0.87
800	427	—	0.84	0.84
1000	538	—	0.81	0.81
1200	649	—	0.39	0.39

Care and Handling of Tubing

Proper control of tubing variables is not only a function of how the tubing is manufactured. Improper care and handling of the tubing can cause correctly manufactured tubing to become unsuitable for use with a tube fitting.

1. Notify Supplier of Need for Careful Handling of Tubing

Not only should tubing be ordered to applicable specifications but appropriate precautions must be taken to protect key tubing characteristics through each handling and preparation phase.

2. Protect Tubing Surface from Damage

A smooth, unscratched tubing surface is essential for achieving a proper seal with a tube fitting. Do not drag straight tubing from storage racks.

3. Uncoil Tubing Correctly

When working with coiled tubing, do not uncoil more than is needed and then recoil. Excessive uncoiling and recoiling will work harden the tubing, potentially increasing surface hardness beyond that which is suitable for use with tube fittings. Uncoil tubing by holding one end and unrolling the coiled section.

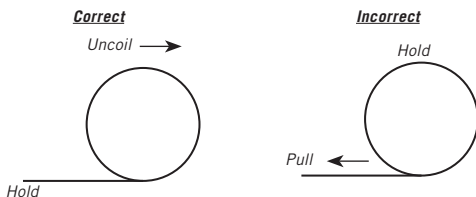

4. Properly Cut Tubing

Tubing must be cut squarely to maximize fitting function. While a hacksaw can be used, HOKE® recommends the use of a tube cutter. Ensure cutting wheel is appropriate for tubing material.

Tube Cutter:

A. Ensure cutting wheel is sharp



B. Insert tubing into tube cutter



- C. Tighten and maintain pressure on the knob which advances the cutting wheel
- D. Cut long lengths of tubing by rocking the cutter above and then below the tubing, assuring full circular cutting. On shorter lengths a continual rotation can be performed. In either case tighten the knob about $\frac{1}{8}$ -turn after every two rotations of the cutter.

Hacksaw:

- A. When cutting tubing with a hacksaw use guideblocks to ensure a square cut and prevent the tubing from flattening out.



5. Deburr Tubing

Cutting tubing, with either a tube cutter or hacksaw, will leave burrs on the tubing. It is important to deburr both the tubing's inside and outside diameters prior to installation. Excessive burring of the tubing outside diameter can damage the fitting during assembly or prevent proper fitting performance. Burrs on the inside diameter of the tubing can break off, enter the fluid stream, and possibly damage critical system components.



After deburring, clean all metal chips from the tubing.

NOTE: Do Not Use Excessively Flattened Tubing

Correctly cut tubing should retain proper roundness. Do not force excessively out-of-round tubing into a fitting. If tubing will not easily insert into fitting, loosen fitting nut to ensure that ferrules are not blocking tube bore. If tubing will still not insert, do not force it; this could cause damage to the tubing and fitting.

Bending the Tubing

As we've already noted, tube bendability is one of the outstanding advantages of using tubing. Careful measurement and accurate bending are essential to achieving desired installation requirements including the achievement of a correct tube and fitting connection.

- 1. Use a tube bender when bending tubing.** By carefully following manufacturer's instructions, suitable bends will be produced.

In order to prevent the problems of flattening, kinking, or wrinkling, use a tube bender and ensure tubing is tightly locked in the bender. If not using a bender, be sure not to bend too short a radius.



- 2. Provide for key bending dimensions.**

R Minimum Bend Radius

L Minimum Length of Straight Tube required to fully bottom tubing in fitting body

Minimum Bend Radius (R)

It is important not to bend too small a radius which will cause excessive ovality and may lead to weakening of the tubing. Use of a proper tube bender will avoid this problem.

Minimum Straight Length of Tube Before Bend (L)

A minimum straight length of tubing before a bend is required to:

- assure full insertion of tubing into fitting, necessary for proper installation
- assure that ferrules are not trying to seal and grip on out-of-round tubing in area of bend
- assure ferrules are contacting area of tubing which has not been work hardened.

As a rule of thumb, when space is not at a premium, allow the following:

- For fractional sizes allow 2" for tubing $\frac{3}{8}$ " and under, 4.5" for tubing $\frac{1}{2}$ " to 1", and 12" for tubing $\frac{1}{4}$ " to 2".
- For metric sizes allow 50mm for tubing 10mm and under, and 120mm for tubing 12mm to 25mm, 300mm for tubing 28mm to 50mm.

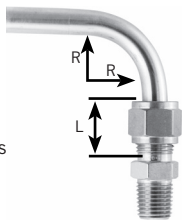

Bending Information Charts

The sum of the 'R' and 'L' dimensions identifies the absolute minimum length of tubing required before the first bending reference mark. Recommended dimensions are shown below.

Fractional-dimensions-(inches)

T TUBE O.D.	R MINIMUM BEND RADIUS	L LENGTH OF STRAIGHT TUBE	RECOMMENDED MINIMUM DISTANCE BEFORE FIRST MARK
1/16"	3/8"	13/32"	27/32"
1/8"	3/8"	19/32"	1"
3/16"	1/2"	5/8"	15/32"
1/4"	9/16"	11/16"	1 17/32"
3/8"	15/16"	3/4"	1 23/32"
1/2"	1 1/2"	31/32"	2 17/32"
5/8"	1 1/2"	11/32"	2 9/16"
3/4"	1 3/4"	11/32"	2 13/16"
7/8"	2"	13/32"	3 1/8"
1"	3"	19/32"	4 3/8"
1 1/4"	5"	2"	7 3/32"
1 1/2"	6"	2 13/32"	8 1/2"
2"	8"	3 1/4"	11 11/32"

Metric-dimensions-(mm)

T TUBE O.D.	R MINIMUM BEND RADIUS	L LENGTH OF STRAIGHT TUBE	RECOMMENDED MINIMUM DISTANCE BEFORE FIRST MARK
3mm	9mm	15mm	25mm
4mm	12mm	16mm	30mm
6mm	14mm	18mm	33mm
8mm	19mm	18mm	38mm
10mm	24mm	19mm	44mm
12mm	38mm	25mm	65mm
14mm	38mm	27mm	65mm
15mm	38mm	27mm	67mm
16mm	38mm	27mm	67mm
18mm	44mm	27mm	74mm
20mm	44mm	27mm	74mm
22mm	50mm	28mm	80mm
25mm	76mm	34mm	112mm
28mm	112mm	40mm	154mm
30mm	120mm	52mm	174mm
32mm	128mm	51mm	180mm
38mm	152mm	60mm	214mm
50mm	200mm	80mm	282mm

3. Designing Tubing Layout

Before marking the tubing for bending, it is important that a complete layout be identified including consideration, where appropriate, of the use of expansion loops, offsets, staggered union locations, and vertical ganging. Always allow sufficient access to utilities and other equipment requiring maintenance.

Expansion Loops

Do not use a straight length of tube to connect two in-line fitting ends. Such an approach makes installation very difficult and does not compensate for temperature change.

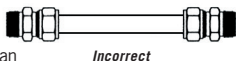

Set the ends so they are not in line and use expansion loops. Expansion loops allow the tubing and entire system to self-compensate for temperature change while not only simplifying assembly and disassembly but also ensuring a safer system.

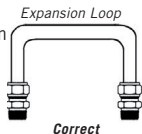

Offset Bends and Staggered Union Locations

Offset bends are used to increase accessibility to tube fitting unions for maintenance purposes. When offsetting in a ganged run, stagger the union locations to further ensure ease of access.



Vertically Gang Tubing

To the maximum extent possible, tubing should be ganged vertically rather than horizontally. Vertical ganging prevents the collection of dirt or any potentially corrosive medium. Vertical ganging additionally increases system safety, since, for example, floor-level horizontally ganged tubing may be stepped on.

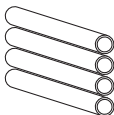

DO

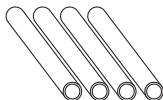

DON'T

4. Marking the Tubing for Bending

Mark the tubing with a pencil using a ferrule as a guide to make a straight line.

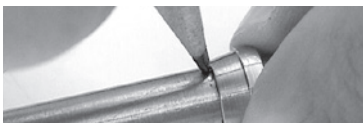

Example: Assume the following layout is required for $\frac{1}{4}$ " tubing:

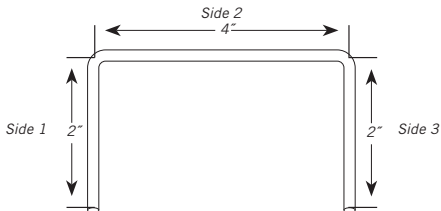

Note: The 2" dimensions at each end do not violate the $\frac{117}{32}$ " minimum straight length dimension required before the first mark from the end.

For accurate bending, **do not** mark the tubing with the dimensions shown above. The tubing runs will be too long and the resultant piece will be asymmetrical. This occurs because when tubing is bent it does not exactly make right angle turns but, in effect, takes short cuts at each bend, as shown below.

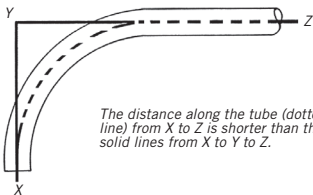

The distance along the tube (dotted line) from X to Z is shorter than the solid lines from X to Y to Z.

The shortcuts create what is called “gain”. Bend gains are as follows:

Tube Bending Gains

TUBE SIZE	90°	45°
1/8"	0.16"	0.02"
3/16"	0.19"	0.02"
1/4"	0.24"	0.02"
3/8"	0.48"	0.05"
1/2"	0.64"	0.06"
5/8"	0.80"	0.08"
3/4"	0.97"	0.10"
7/8"	1.13"	0.11"
1"	1.29"	0.13"
1 1/4"	1.61"	0.16"
1 1/2"	1.94"	0.20"
2"	2.58"	0.26"

Required Length of Tubing

Using the layout on the previous page, the actual tubing length required is 7.52", calculated as follows:

[Side 1 length (2")] + [Side 2 length (4") – Gain for first 90° bend (0.24")] + [Side 3 length (2") – Gain for second 90° bend (0.24")]

$$2" + [4" - 0.24"] + [2" - 0.24"] = 7.52"$$

Marking the Tubing

Mark the tubing based on the brackets [] shown above:

- First mark: 2"
- Second mark: $4" - 0.24" = 3.76"$
- Third mark for cutting: $2" - 0.24" = 1.76"$

To ensure best fit, we recommend not cutting until bending is complete.

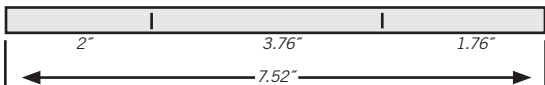

Offset Bends

While 90° bends are most commonly used in tubing layouts, offset bends of 30°, 45°, or 60° are

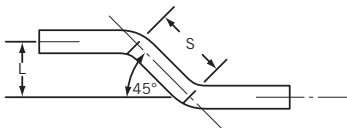

frequently used for maintenance purposes. As shown in the drawing above, the length of offset (S) is considerably more than the amount of offset (L).

The specific length required for the offset, which is what will need to be marked for bending, is determined by multiplying the amount of offset by an amount specific to the offset angle.

Offset Calculations

OFFSET ANGLE	MULTIPLIER
30°	2
45°	1.414
60°	1.155

Example: As shown above, the specific length of tubing required to provide 1" of offset with a 30° angle is 2":

Offset Amount (1") × Multiplier for 30° Angle (2) = 2" Offset Length

Use the following chart to determine the appropriate offset length for a given amount of offset.

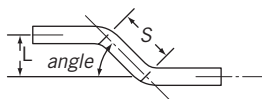

Offset Bend Dimensions (dimensions in inches)

30° OFFSET		45° OFFSET	
L	S	L	S
1"	2"	1"	1 ¹³ / ₃₂ "
1 ¹ / ₈ "	2 ¹ / ₄ "	1 ¹ / ₈ "	1 ¹⁹ / ₃₂ "
1 ¹ / ₄ "	2 ¹ / ₂ "	1 ¹ / ₄ "	1 ²⁵ / ₃₂ "
1 ³ / ₈ "	2 ³ / ₄ "	1 ³ / ₈ "	1 ¹⁵ / ₁₆ "
1 ¹ / ₂ "	3"	1 ¹ / ₂ "	2 ¹ / ₈ "
1 ⁵ / ₈ "	3 ¹ / ₄ "	1 ⁵ / ₈ "	2 ⁵ / ₁₆ "
1 ³ / ₄ "	3 ¹ / ₂ "	1 ³ / ₄ "	2 ¹⁵ / ₃₂ "
1 ⁷ / ₈ "	3 ³ / ₄ "	1 ⁷ / ₈ "	2 ²¹ / ₃₂ "
2"	4"	2"	2 ¹³ / ₁₆ "
2 ¹ / ₈ "	4 ¹ / ₄ "	2 ¹ / ₈ "	3"
2 ¹ / ₄ "	4 ¹ / ₂ "	2 ¹ / ₄ "	3 ³ / ₁₆ "
2 ³ / ₈ "	4 ³ / ₄ "	2 ³ / ₈ "	3 ¹¹ / ₃₂ "
2 ¹ / ₂ "	5"	2 ¹ / ₂ "	3 ¹⁷ / ₃₂ "
2 ⁵ / ₈ "	5 ¹ / ₄ "	2 ⁵ / ₈ "	3 ²³ / ₃₂ "
2 ³ / ₄ "	5 ¹ / ₂ "	2 ³ / ₄ "	3 ⁷ / ₈ "
2 ⁷ / ₈ "	5 ³ / ₄ "	2 ⁷ / ₈ "	4 ¹ / ₁₆ "
3"	6"	3"	4 ¹ / ₄ "
3 ¹ / ₈ "	6 ¹ / ₄ "	3 ¹ / ₈ "	4 ¹³ / ₃₂ "
3 ¹ / ₄ "	6 ¹ / ₂ "	3 ¹ / ₄ "	4 ¹⁹ / ₃₂ "
3 ³ / ₈ "	6 ³ / ₄ "	3 ³ / ₈ "	4 ²⁵ / ₃₂ "
3 ¹ / ₂ "	7"	3 ¹ / ₂ "	4 ¹⁵ / ₁₆ "
3 ⁵ / ₈ "	7 ¹ / ₄ "	3 ⁵ / ₈ "	5 ¹ / ₈ "
3 ³ / ₄ "	7 ¹ / ₂ "	3 ³ / ₄ "	5 ⁵ / ₁₆ "
3 ⁷ / ₈ "	7 ³ / ₄ "	3 ⁷ / ₈ "	5 ¹⁵ / ₃₂ "
4"	8"	4"	5 ²¹ / ₃₂ "

5. Bending the Tubing

Best bends are produced by using tube benders specific to the tubing size.



Note the proper callout of tube size on the bender.

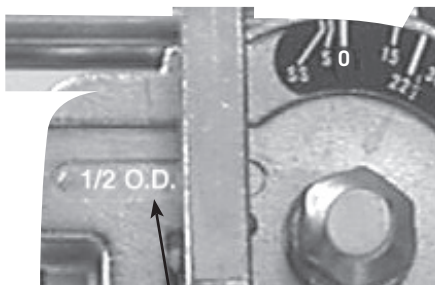

Tube Size

90° Bends

Locate the mark in the bender so that it is tangent to the 90° mark on the bender's dial. Lock the tubing in place to avoid problem bends.

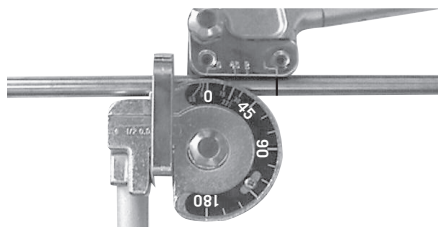

Bend the tubing by smoothly swinging the upper arm down. Align the “0” on the upper arm with the “90” on the dial. Allow for about 3° of springback.

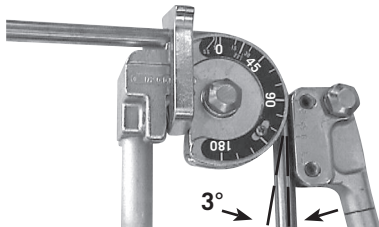

Reverse Bends

Since benders only bend in one direction, it is critical when reverse bending to ensure that the tubing is properly aligned in the bender.

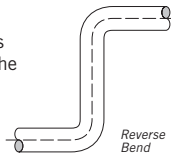

Offset Bends

Locate the mark in the bender so that it lines up with the desired offset angle on the dial. Smoothly swing the upper arm until the zero on the upper arm aligns with the desired offset angle on the dial.

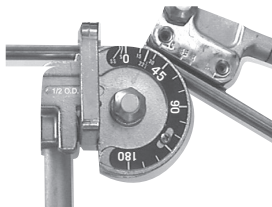

Tube Clamping

Never support instruments or tubing with the tube fitting. Use clamps. Tube support by clamping is necessary to reduce shock and vibration which may affect performance. The clamp should be placed close to each bend and then periodically, as shown in chart below, for long straight lengths.

TUBE O.D.		SPACING BETWEEN CLAMPS	
INCH	MM	FT	METERS
1/4–1/2	6–12	3	.9
5/8–7/8	14–22	4	1.2
1	25	5	1.5
1 1/4–2	32–50	7	2.1

GYROLOK® Assembly Instructions

0-1/2" (12mm)
MANUAL ASSEMBLY

1/2" – 1" (12mm-25mm)
MANUAL OR HPST ASSEMBLY
based on installation conditions

Manual Assembly Instructions

Use of a PST (Manual Pre Setting Tool) is **recommended**
GYROLOK® Marking Tool (GMT) is **strongly recommended**.

Fully insert a correctly cut, deburred tube into the PST or fitting body until the tube rests on the sizing angle.

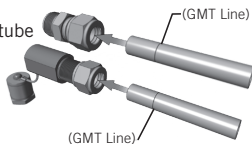

Holding the tube in the PST or Body, extract the nut and ferrules to visually ensure both ferrules are correctly oriented.

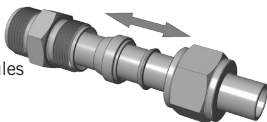

Once correct ferrule orientation is confirmed, thread & rotate the nut onto the PST or Body until hand-tight. The GMT witness line should **NOT** be visible.

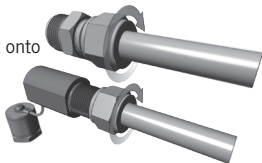

Establish a reference point for wrench tightening by marking both the fitting body and nut.

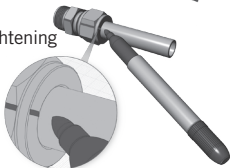

While supporting the PST or fitting body, tighten the nut with a wrench 1 1/4 turns. The pre-set or make-up is now complete. Confirm that the GMT witness line is now visible.

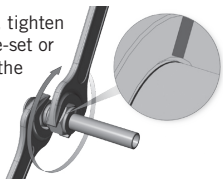

½" – 1" (12mm-25mm)
MANUAL OR HPST ASSEMBLY
based on installation conditions

Above 1" (25mm)
HPST ASSEMBLY
consult factory as needed

HPST Assembly Instructions

GYROLOK® Marking Tool (GMT) is **strongly recommended**.

Ensure the HPST Tooling Set is installed with the proper indicator nut.

Fully insert a correctly cut, deburred tube into the HPST head. Visually ensure both ferrules are correctly oriented. Thread & rotate the nut until hand-tight.

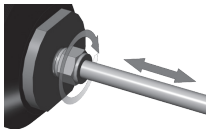

Set the indicator arm in the operating position by rotating the Indicator Nut counter-clockwise until it stops.



Pump the handle until the indicator arm releases.

CAUTION: Stop pumping immediately after the arm releases, as over-pumping may cause the tube to swell and stick. Pre-setting is now complete.

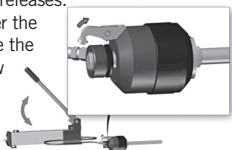

Insert the end with pre-set ferrules and nut into the fitting. Thread and rotate the nut until hand-tight. While supporting the fitting body, tighten the nut with a wrench ½ turn for tubing up to 1" (25mm). For tubing greater than 1" (25mm) ¾ turn is required. The initial fitting make-up is now complete.

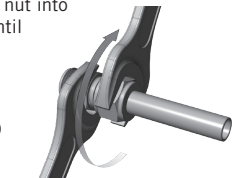

GYROLOK® MARKING TOOL (GMT) INSTRUCTIONS

Insert the correctly cut and deburred tube into the GMT as far as possible.

Mark the tubing as shown with an Ultra-Fine Point, Chloride-Free pen (recommended Sharpie Model 37001). Take care to position the marker perpendicular to the GMT, or in sufficient ferrule set could occur.

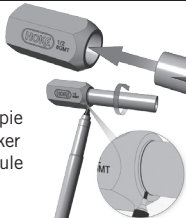

REMAKE INSTRUCTIONS

Firmly insert end with the correctly set ferrules & nut into the fitting. Thread & rotate the nut until hand-tight. The GMT witness line should **NOT** be visible.



While supporting the fitting body, tighten the nut with a wrench ¼ turn.

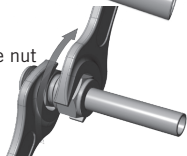

PLUGS & PORT CONNECTORS

Remove and discard ferrules. Firmly insert the plug or port connector into the end connection and hand-tighten the nut.

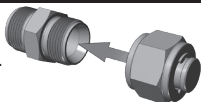

While supporting the fitting body, tighten the nut with a wrench ¼ turn.

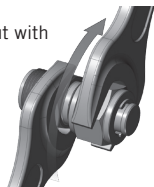

TUBE ADAPTERS & REDUCERS

For this type of fitting please follow the Manual Assembly Instructions.

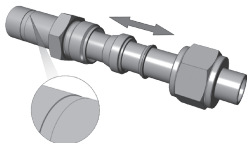

MALE NUT (INTEGRAL) PST INSTRUCTIONS

For this type of fitting please follow the Manual Assembly Instructions. After PST is used, assemble fitting to body and follow standard Remake Instructions

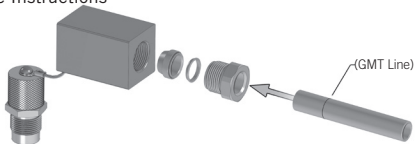

Installation Aids

1. Installation Gage

To achieve a proper installation, it is necessary to:

- Verify all components are present
- Insure proper insertion of the tubing into the fitting
- Confirm sufficient tightening of the fitting nut

The GYROLOK® Marking Tools provide each of these checks, when used with GYROLOK® fittings, to ensure maximum safety.



Three-In-One GMT
(468GMT and
61012 GMTMM)

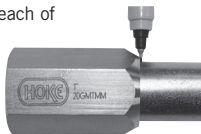

Standard GMT

2. Hydraulic Presetting Tool

Presetting tools simplify hard-to-reach installations, or installation of larger size tubing. HOKE® recommends the use of its hydraulic presetting tool to preset nut and ferrules when installing tubing with a diameter of 5/8" (16mm) or larger and a wall thickness of 0.065" (2.0mm) or greater.



Hydraulic Presetting Tool

Part #3HPST (Order with appropriate die & jig sets)

3. Manual Presetting Tool

A manual presetting tool is also available for 1" and under sizes of GYROLOK® fittings and is particularly well suited for applications where the installation is in a hard-to-reach location.



Manual Presetting Tool
Part# PST

4. Tube Stub Adapters

A tube stub adapter is an excellent tool to use when faced with possible alignment problems. Consider the following situation.

- **Situation:** Need to join tubing and female NPT port at 90° angle to one another



- **Problem:** With the NPT end properly assembled, the tube fitting end of a male elbow may not properly line up with the tubing.



- **Solution:** Use a male tube stub adapter to convert the female port to a tube stub end.



- **Assembly:** Then simply use a union elbow to make the required connections.



5. Port Connectors

Use port connectors for close connecting one tube fitting to another. Port connector installation is accomplished as follows:

- Remove nut and ferrules from first port.

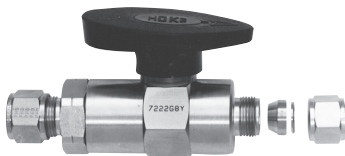

- Firmly insert machined ferrule end of port connector into tube fitting port.

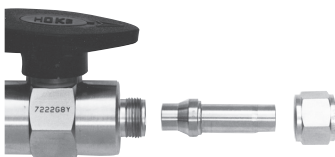

- Place nut over machined ferrule and finger tighten. Using wrench, turn nut until sharp rise in torque is felt, then simply snug.



- Insert tube stub end into tube fitting port and follow initial assembly instructions to complete installation.

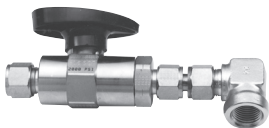

6. Nut and Ferrule Safety Changer

A nut and ferrule safety changer provides the safest method of replacing fitting components by eliminating the need for ferrule handling while ensuring proper ferrule orientation.



Safety Changer

- To use a nut and ferrule safety changer, insert the changer end into the fitting body, lightly thread the nut onto the body, and simply extract safety changer from nut



7. Bleed Valves

Bleed valve nuts are crimped for safety. Loosen bleed valve nut to relieve system pressure. Never loosen the fitting nut to relieve or bleed system pressure. Bleed fittings are specifically designed to perform this function.

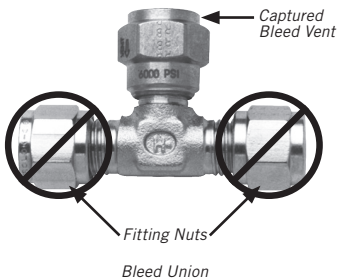

8. Tube Inserts

Tube inserts are used to support soft pliable plastic tubing to insure safe system performance. With GYROLOK®, simply place the tube insert into the tubing end and then follow standard initial assembly instructions.



Tube Insert



Installing Tube Insert

9. Sacrificial Pipe Fittings

Use sacrificial pipe fittings to protect expensive equipment. When pipe threads are frequently assembled and reassembled, the thread's ability to maintain a seal may diminish. In order to maximize the functional life of valuable equipment, insert a sacrificial pipe fitting between the pipe and the equipment. Perform makes and breaks between the pipe and pipe fitting to extend the life of the equipment.



Pipe

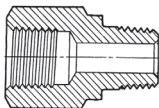

Sacrificial Fitting

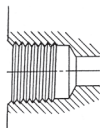

Equipment Port

WARNING

Improper selection or use of products described herein can cause Personal injury or property damage

Product information described herein is offered for use by the system designer and user.

It is solely the responsibility of the system designer and user to select products suitable for their specific application requirements and to ensure proper installation, operation and maintenance of these products. Material compatibility, product ratings, and application details should be considered in the selection.

Always contact your local HOKE® Distributor with any questions you may have before pressurizing and operating the product.

Safety Instructions

1. Do not tighten or loosen any part of a fitting or valve when the system is pressurized. Make sure the system is un-pressurized when tightening or loosening a fitting or valve connection.
2. Do not loosen GYROLOK® nut or any product component in order to relieve or bleed down system pressure.
3. Do not exceed pressure-temperature specifications stated in the appropriate catalog.
4. When the application involves use of a toxic or hazardous fluid, exercise extra caution during operation and maintenance.
5. Before assembling new, unused GYROLOK® tube fitting ends, loosen the GYROLOK® nut before inserting the tube to allow full insertion of the tube to the base of the body bore.
6. Always use tubing that is compatible with the fitting or valve material. Tubing appropriate for use with HOKE® products is described in Tubing Data Charts. For example, use 316 Stainless Steel fittings with 316 Stainless Steel tubing.
7. Always leave a length of straight tube between the tube bend and the fitting. A tube bent too close to the fitting connection may be a source of leakage.
8. During assembly of the GYROLOK® tube end, always hold the fitting or valve body with one wrench while separately wrench tightening the GYROLOK® nut. Follow the same precaution when disassembling.
9. Always use a HOKE® tube insert (basic part number "TI") when assembling a GYROLOK® fitting to soft, pilable plastic tubing.
10. Always use proper thread lubricants or sealants on tapered pipe threads. Note that thread sealants may have lower temperature ratings than the basic fitting.
11. When installing an NPT ended valve, hold the valve body near the connection with one wrench, while separately wrench tightening the mating pipe. Turn the pipe, not the valve. Follow the same precaution when disconnecting.
12. Do not hold the valve handle when tightening an end connection.
13. Do not use excessive force to open or close a ball valve e.g. do not use a handle extension.
14. On initial installation, valves may require an adjustment of the packing nut due to storage variations, systems parameters, and cold flow properties of TFE.

SAFETY WARNING:

GYROLOK® products are designed for installation only by professional suitably qualified licensed system installers experienced in the applications and environments for which the products are intended. These products are intended for integration into a system. Where these products are to be used with flammable or hazardous media, precautions must be taken by the system designer and installer to ensure the safety of persons and property. Flammable or hazardous media pose risks associated with fire or explosion, as well as burning, poisoning or other injury or death to persons and/or destruction of property. The system designer and installer must provide for the capture and control of such substances from any vents in the product(s). The system installer must not permit any leakage or uncontrolled escape of hazardous or flammable substances. The system operator must be trained to follow appropriate precautions and must inspect and maintain the system and its components including the product(s) and at regular intervals in accordance with timescales recommended by the supplier to prevent unacceptable wear or failure.

INSTRUMENT TUBING CONNECTION WORK PROCESS AND ASSEMBLY PRACTICES:

General

- This pressure test portion of this policy pertains only to tubing connections in process service and on steam tracing. The policy is not intended for use on tubing connections in instrument air service.
- This policy is intended for new tubing connections.
- The specified assembly procedure is based on the use of compression type joint designs that utilize a two-ferrule system.
- The specified assembly procedure is only intended for use on 1/4", 3/8" and 1/2" tubing connections.
- The specified procedure is suitable for both systems which utilize both types 316 and 304 stainless steel as well as alloy 825 tubing mating to type 316 stainless steel fittings.
- When practical, field fabricated tubing connections should be assembled progressively away from the equipment that they will be connected to.
- The craftsman that is assembling and tightening the tubing connections must have completed the MPO onsite tubing connection assembly training.
- Pressure tests on tubing must be done prior to loop check.
- Additional details on the installation, inspection, and testing shall be in accordance with all applicable specifications in Section 16 of the Shell Engineering Guides and General Standards (EGGS) for Process Control.

General Information

How to Order

The GYROLOK® numbering system is a completely descriptive system that's easy to understand. Each part number describes completely assembled fittings.

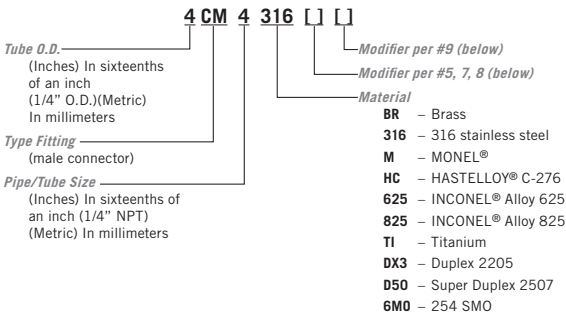

1. The first number (4) identifies the tube O.D. size.
For example, 4 = 4/16" for fractional fittings. 4 = 4mm for metric fittings. If there is no 5th group, sizes are fractional.
2. The letter group, (CM) identifies the type of fitting (Male Connector). See fitting locator, pages 2 and 3.
3. The third group, a number (4), is only necessary if the second tube connection size is different from the first tube O.D. size. For pipe sizes, a number is always required.
4. Material is identified in the fourth group.

General Information cont'd

How to Order cont'd

5. With the exception of branch tees, the fifth group, if present, contains two letter codes. The first letter designates the unit of measure for the first number in the part number—i.e, E for fractional, M for metric. The second letter indicates the unit of measure (E or M), or thread type, for the second number in the part number. If there is no 5th group, all sizes are fractional.

Examples:

4CM4316 = 1/4 tube x 1/4 NPT male connector,
316 stainless steel

6RU3BRME = 6mm tube x 3/16 tube reducing union, brass

8LM4316EC = 1/2 tube x 1/4 male RT, male elbow, 316
stainless steel

Unit of measure/end connector codes:

A = RS male ends

M = Metric tube, in millimeters

B = RP male ends

X = RS/RP female ends

C = RT ends

Z = RG female ends

E = fractional unit of measure in 1/16th of an inch

6. Tee part numbering: TEES are described by first the run (1 and 2) and next the branch (3), for example:

TTM describes a tee that has tube connections at 1 and 2 and a male pipe thread at position 3.

TFT describes a tee that has tube connections at 1 and 3 and a female pipe thread at position 2.

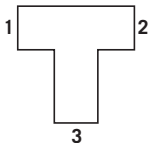

7. Fittings cleaned for oxygen service: To order, add HPS18 to the end of basic fitting part number.

Example: **4CM4316HPS18**

8. Fittings cleaned for nuclear service: To order, add HPS 90 to the end of basic fitting part number.

Example: **4CM4316HPS90**

9. O-ring designator - Viton® (45) is standard for SAE fittings. In the event no material is specified, Viton will be supplied. Buna (21) is standard for other fittings with O-rings. Alternative O-ring materials are available, including silicone (01), and Buna-N (23). Example **6CMS631623**

GYROLOK® Fittings-Dimensional & Application Tables

Male Connector: CM, CM/EC

connects fractional tube to female NPT or RT threads

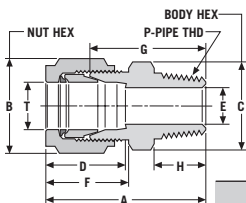

Dimensions — inches

Part Number*		T	P Male
NPT Threads	RT Threads	Tube O.D.	NPT Size
1CM1[]	—	1/16	1/16
1CM2[]	—	1/16	1/8
1CM4[]	—	1/16	1/4
2CM1[]	—	1/8	1/16
2CM2[]	2CM2[]EC	1/8	1/8
2CM4[]	2CM4[]EC	1/8	1/4
3CM2[]	—	3/16	1/8
3CM4[]	3CM4[]EC	3/16	1/4
4CM1[]	—	1/4	1/16
4CM2[]	4CM2[]EC	1/4	1/8
4CM4[]	4CM4[]EC	1/4	1/4
4CM6[]	4CM6[]EC	1/4	3/8
4CM8[]	4CM8[]EC	1/4	1/2
4CM12[]	—	1/4	3/4
6CM2[]	6CM2[]EC	3/8	1/8
6CM4[]	6CM4[]EC	3/8	1/4
6CM6[]	6CM6[]EC	3/8	3/8
6CM8[]	6CM8[]EC	3/8	1/2
6CM12[]	—	3/8	3/4
8CM2[]	—	1/2	1/8
8CM4[]	8CM4[]EC	1/2	1/4
8CM6[]	8CM6[]EC	1/2	3/8
8CM8[]	8CM8[]EC	1/2	1/2
8CM12[]	8CM12[]EC	1/2	3/4
8CM16[]	—	1/2	1
10CM6[]	—	5/8	3/8
10CM8[]	10CM8[]EC	5/8	1/2
10CM12[]	—	5/8	3/4
12CM8[]	—	3/4	1/2
12CM12[]	—	3/4	3/4
12CM16[]	—	3/4	1
14CM12[]	—	7/8	3/4
16CM8[]	—	1	1/2
16CM12[]	—	1	3/4
16CM16[]	—	1	1
20CM16[]	—	1 1/4	1
20CM20[]	—	1 1/4	1 1/4
24CM24[]	—	1 1/2	1 1/2
32CM32[]	—	2	2

* [] see page 59-60 for material specifications.

Male Connector: CM/ME, CM/MC

connects **metric** tube with NPT or RT tapered threads

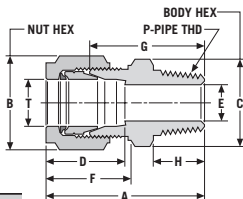

Dimensions — mm

Part Number*		T	P
NPT Threads	RT Threads	Tube O.D.	Pipe Thd.
3CM2[]ME	3CM2[]MC	3	1/8
3CM4[]ME	3CM4[]MC	3	1/4
4CM2[]ME	4CM2[]MC	4	1/8
4CM4[]ME	4CM4[]MC	4	1/4
6CM2[]ME	6CM2[]MC	6	1/8
6CM4[]ME	6CM4[]MC	6	1/4
6CM6[]ME	6CM6[]MC	6	3/8
6CM8[]ME	6CM8[]MC	6	1/2
6CM12[]ME	6CM12[]MC	6	3/4
8CM2[]ME	8CM2[]MC	8	1/8
8CM4[]ME	8CM4[]MC	8	1/4
8CM6[]ME	8CM6[]MC	8	3/8
8CM8[]ME	8CM8[]MC	8	1/2
8CM12[]ME	8CM12[]MC	8	3/4
10CM2[]ME	10CM2[]MC	10	1/8
10CM4[]ME	10CM4[]MC	10	1/4
10CM6[]ME	10CM6[]MC	10	3/8
10CM8[]ME	10CM8[]MC	10	1/2
12CM4[]ME	12CM4[]MC	12	1/4
12CM6[]ME	12CM6[]MC	12	3/8
12CM8[]ME	12CM8[]MC	12	1/2
12CM12[]ME	12CM12[]MC	12	3/4
14CM4[]ME	14CM4[]MC	14	1/4
14CM6[]ME	14CM6[]MC	14	3/8
14CM8[]ME	14CM8[]MC	14	1/2
15CM8[]ME	15CM8[]MC	15	1/2
16CM6[]ME	16CM6[]MC	16	3/8
16CM8[]ME	16CM8[]MC	16	1/2
16CM12[]ME	16CM12[]MC	16	3/4
18CM8[]ME	18CM8[]MC	18	1/2
18CM12[]ME	18CM12[]MC	18	3/4
20CM8[]ME	20CM8[]MC	20	1/2
20CM12[]ME	20CM12[]MC	20	3/4
22CM8[]ME	22CM8[]MC	22	1/2
22CM12[]ME	22CM12[]MC	22	3/4
22CM16[]ME	22CM16[]MC	22	1
25CM12[]ME	25CM12[]MC	25	3/4
25CM16[]ME	25CM16[]MC	25	1
30CM16[]ME	—	30	1
30CM20[]ME	—	30	1 1/4
32CM16[]ME	—	32	1
38CM16[]ME	—	38	1
38CM20[]ME	—	38	1 1/4
38CM24[]ME	—	38	1 1/2

* [] see page 59-60 for material specifications.

Bulkhead Connector, Male: BCM

connects fractional tube to female NPT threads

Dimensions — inches

Part Number*	T Tube O.D.	P Pipe Size
2BCM2[]	1/8	1/8
2BCM4[]	1/8	1/4
3BCM2[]	3/16	1/8
4BCM2[]	1/4	1/8
4BCM4[]	1/4	1/4
6BCM4[]	3/8	1/4
6BCM6[]	3/8	3/8
6BCM8[]	3/8	1/2
8BCM6[]	1/2	3/8
8BCM8[]	1/2	1/2



Metric fitting shown

Bulkhead Connector, Male: BCM/ME

connects metric tube to female NPT threads

Dimensions — mm

Part Number*	T Tube O.D.	P Pipe Thd.
3BCM2[]ME	3	1/8
6BCM2[]ME	6	1/8
6BCM4[]ME	6	1/4
6BCM6[]ME	6	3/8
6BCM8[]ME	6	1/2
8BCM4[]ME	8	1/4
10BCM2[]ME	10	1/8
10BCM4[]ME	10	1/4
10BCM6[]ME	10	3/8
12BCM6[]ME	12	3/8
12BCM8[]ME	12	1/2
14BCM8[]ME	14	1/2
16BCM8[]ME	16	1/2
18BCM8[]ME	18	1/2
22BCM8[]ME	22	1/2
25BCM8[]ME	25	1/2

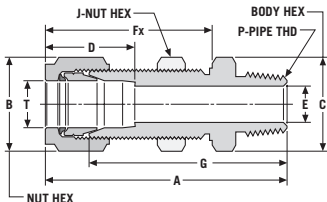

* [] see page 59-60 for material specifications.

Male Connector, SAE: CMS

connects **fractional** tube to SAE straight thread boss

Dimensions — inches

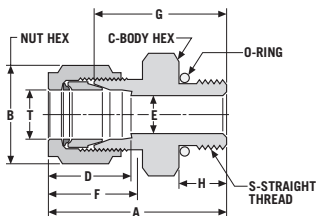
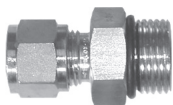

Part Number*	T	S
2CMS2[]	1/8	5/16-24
4CMS4[]	1/4	7/16-20
4CMS6[]	1/4	9/16-18
4CMS8[]	1/4	3/4-16
4CMS10[]	1/4	7/8-14
6CMS4[]	3/8	7/16-20
6CMS6[]	3/8	9/16-18
6CMS8[]	3/8	3/4-16
6CMS10[]	3/8	7/8-14
8CMS6[]	1/2	9/16-18
8CMS8[]	1/2	3/4-16
8CMS12[]	1/2	1 1/16-12
10CMS10[]	5/8	7/8-14
12CMS8[]	3/4	3/4-16
12CMS12[]	3/4	1 1/16-12
16CMS12[]	1	1 1/16-12
16CMS16[]	1	1 5/16-12
20CMS20[]	1 1/4	1 5/8-12
24CMS24[]	1 1/2	1 7/8-12
32CMS32[]	2	2 1/2-12

* [] see page 59-60 for material specifications.

Long Male Connector, SAE: LCMS

connects fractional tube to SAE straight thread boss

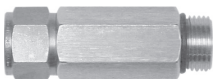

Dimensions — inches

Part Number*	T	
	Tube O.D.	S
4LCMS4[]	1/4	7/16-20
6LCMS6[]	3/8	9/16-18
8LCMS8[]	1/2	3/4-16
12LCMS12[]	3/4	1 1/16-12
16LCMS16[]	1	1 5/16-12

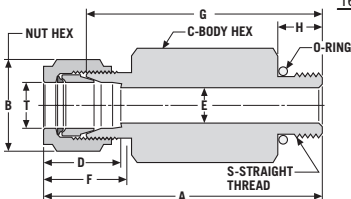

O-ring Installation Instructions

GYROLOK® O-ring seal fittings are used for direct connection to existing pipe thread or straight thread ports—which have a smooth, flat surface perpendicular to the threaded port. O-ring seal fittings provide leak-tight sealing on both vacuum and high pressure systems. In the pipe thread version, a special short thread insures against thread interference.

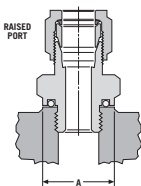

Fig. 1

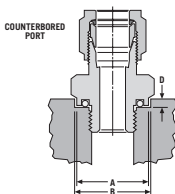

Fig. 2

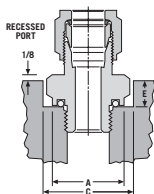

Fig. 3

* [] see page 59-60 for material specifications.

O-ring Installation Instructions – cont.

Mounting Dimensions For O-ring Seal Connectors and Adapters

The standard Buna N O-ring is completely contained in a precision groove, to prevent O-ring extrusion at high pressure. The precision groove also provides a controlled squeeze for a vacuum-tight seal.

The chart lists pertinent dimensions useful with O-ring seal connectors and adapters.

When installing an O-ring port:

1. Hand-thread until the O-ring compresses on the port end.
2. Snug the fitting to the port with a wrench to completely compress the O-ring.
3. Always use a back-up wrench to hold the O-ring seal fitting body, when connecting or disconnecting a GYROLOK® end.

Dimensions — inches

Straight Thread Size*	Pipe Thread Size**
5/16-24	—
3/8-24	—
7/16-20	—
1/2-20	—
9/16-18	—
3/4-16	—
7/8-14	—
1 1/16-12	—
1 5/16-12	—
—	1/8 NPT
—	1/4 NPT
—	3/8 NPT
—	1/2 NPT
—	3/4 NPT
—	1 NPT

O-ring Straight Connector: COS

connects fractional tube to female straight thread



Dimensions — inches

Part Number*	T Tube O.D.	S Thread Size
1COS[]	1/16	5/16-24
2COS[]	1/8	5/16-24
3COS[]	3/16	3/8-24
4COS[]	1/4	7/16-20
6COS[]	3/8	9/16-18
8COS6[]	1/2	9/16-18
8COS[]	1/2	3/4-16
10COS[]	5/8	7/8-14
12COS[]	3/4	1 1/16-12
16COS[]	1	1 5/16-12

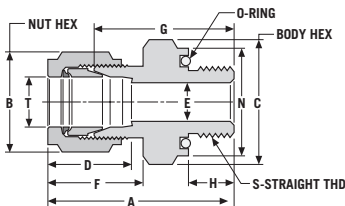

* [] see page 59-60 for material specifications.

O-ring Male Connector: COM

connects fractional tube to female NPT threads

Dimensions — inches

Part Number*	T Tube O.D.	P Pipe Thd.
1COM2[]	1/16	1/8
2COM2[]	1/8	1/8
2COM4[]	1/8	1/4
3COM2[]	3/16	1/8
3COM4[]	3/16	1/4
4COM2[]	1/4	1/8
4COM4[]	1/4	1/4
4COM6[]	1/4	3/8
6COM2[]	3/8	1/8
6COM4[]	3/8	1/4
6COM6[]	3/8	3/8
6COM8[]	3/8	1/2
8COM4[]	1/2	1/4
8COM6[]	1/2	3/8
8COM8[]	1/2	1/2
10COM8[]	5/8	1/2
10COM12[]	5/8	3/4
12COM8[]	3/4	1/2
12COM12[]	3/4	3/4
16COM12[]	1	3/4
16COM16[]	1	1

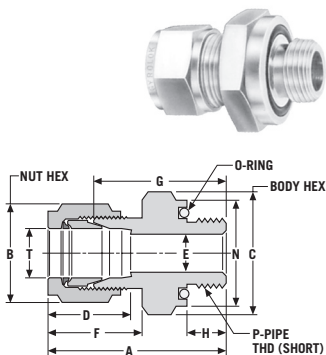

Male Connector: CM/EB

connects fractional tube with RP parallel threads

Dimensions — inches

Part Number*	T Tube O.D.	S Thd. Size
2CM2[]EB	1/8	1/8
2CM4[]EB	1/8	1/4
4CM2[]EB	1/4	1/8
4CM4[]EB	1/4	1/4
4CM6[]EB	1/4	3/8
4CM8[]EB	1/4	1/2
6CM4[]EB	3/8	1/4
6CM6[]EB	3/8	3/8

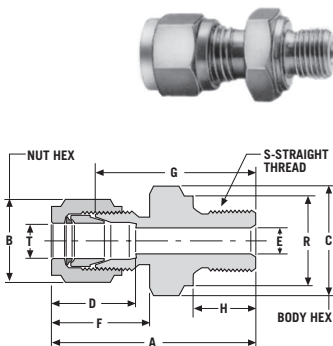

* [] see page 59-60 for material specifications.

Male Connector: CM/MB

connects **metric** tube with RP parallel threads

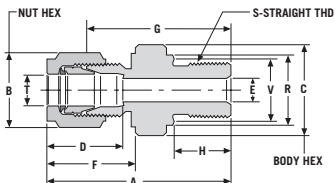

NOTE: RP parallel thread ends are typically used with a flat gasket to seal.

* [] see page 59-60 for material specifications.

Dimensions — mm

Part Number*	T	S
	Tube O.D.	Straight Thd.
3CM2[]MB	3	1/8
3CM4[]MB	3	1/4
6CM2[]MB	6	1/8
6CM4[]MB	6	1/4
6CM6[]MB	6	3/8
6CM8[]MB	6	1/2
8CM2[]MB	8	1/8
8CM4[]MB	8	1/4
8CM6[]MB	8	3/8
8CM8[]MB	8	1/2
8CM12[]MB	8	3/4
10CM2[]MB	10	1/8
10CM4[]MB	10	1/4
10CM6[]MB	10	3/8
10CM8[]MB	10	1/2
12CM4[]MB	12	1/4
12CM6[]MB	12	3/8
12CM8[]MB	12	1/2
12CM12[]MB	12	3/4
14CM4[]MB	14	1/4
14CM6[]MB	14	3/8
14CM8[]MB	14	1/2
15CM8[]MB	15	1/2
16CM6[]MB	16	3/8
16CM8[]MB	16	1/2
16CM12[]MB	16	3/4
18CM8[]MB	18	1/2
18CM12[]MB	18	3/4
20CM8[]MB	20	1/2
22CM8[]MB	22	1/2
22CM12[]MB	22	3/4
22CM16[]MB	22	1
25CM12[]MB	25	3/4
25CM16[]MB	25	1

Male Connector: CM/EA

connects **fractional** tube with RS parallel threads

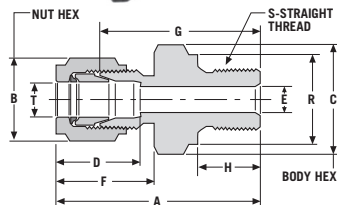

Dimensions — inches

Part Number*	T	S
	Tube O.D.	Thd. Size
2CM2[]EA	1/8	1/8
2CM4[]EA	1/8	1/4
2CM6[]EA	1/8	3/8
4CM2[]EA	1/4	1/8
4CM4[]EA	1/4	1/4
4CM6[]EA	1/4	3/8
4CM8[]EA	1/4	1/2
6CM4[]EA	3/8	1/4
6CM6[]EA	3/8	3/8
6CM8[]EA	3/8	1/2
8CM4[]EA	1/2	1/4
8CM6[]EA	1/2	3/8
8CM8[]EA	1/2	1/2
12CM8[]EA	3/4	1/2
12CM12[]EA	3/4	3/4
16CM8[]EA	1	1/2
16CM16[]EA	1	1

Male Connector: CM/MA

connects **metric** tube with RS parallel threads

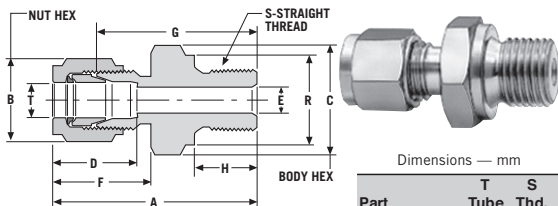

Dimensions — mm

Part Number*	T Tube Size	S Thd. Size
3CM2[]MA	3	1/8
3CM4[]MA	3	1/4
6CM2[]MA	6	1/8
6CM4[]MA	6	1/4
6CM6[]MA	6	3/8
6CM8[]MA	6	1/2
8CM2[]MA	8	1/8
8CM4[]MA	8	1/4
8CM6[]MA	8	3/8
8CM8[]MA	8	1/2
8CM12[]MA	8	3/4
10CM2[]MA	10	1/8
10CM4[]MA	10	1/4
10CM6[]MA	10	3/8
10CM8[]MA	10	1/2
12CM4[]MA	12	1/4
12CM6[]MA	12	3/8
12CM8[]MA	12	1/2
12CM12[]MA	12	3/4
14CM4[]MA	14	1/4
14CM6[]MA	14	3/8
14CM8[]MA	14	1/2
15CM8[]MA	15	1/2
16CM6[]MA	16	3/8
16CM8[]MA	16	1/2
16CM12[]MA	16	3/4
18CM8[]MA	18	1/2
18CM12[]MA	18	3/4
20CM8[]MA	20	1/2
22CM8[]MA	22	1/2
22CM12[]MA	22	3/4
22CM16[]MA	22	1
25CM12[]MA	25	3/4
25CM16[]MA	25	1

NOTE: RP parallel thread ends are typically used with a gasket having a bonded elastomer seal. RP-type gaskets may also be used.

* [] see page 59-60 for material specifications.

Male Elbow: LM

connects **fractional** tube to female NPT thread

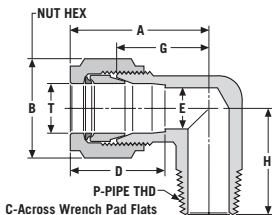

Dimensions — inches

Part Number*	T Tube O.D.	P Male NPT Size
1LM1 []	1/16	1/16
1LM2 []	1/16	1/8
2LM1 []	1/8	1/16
2LM2 []	1/8	1/8
2LM4 []	1/8	1/4
3LM2 []	3/16	1/8
3LM4 []	3/16	1/4
4LM2 []	1/4	1/8
4LM4 []	1/4	1/4
4LM6 []	1/4	3/8
4LM8 []	1/4	1/2
6LM2 []	3/8	1/8
6LM4 []	3/8	1/4
6LM6 []	3/8	3/8
6LM8 []	3/8	1/2
8LM4 []	1/2	1/4
8LM6 []	1/2	3/8
8LM8 []	1/2	1/2
8LM12 []	1/2	3/4
10LM6 []	5/8	3/8
10LM8 []	5/8	1/2
12LM8 []	3/4	1/2
12LM12 []	3/4	3/4
16LM12 []	1	3/4
16LM16 []	1	1
20LM20 []	1 1/4	1 1/4
24LM24 []	1 1/2	1 1/2
32LM32 []	2	2

* [] see page 59-60 for material specifications.

Male Elbow: LM/ME, LM/MC

connects **metric** tube with NPT or RT tapered threads

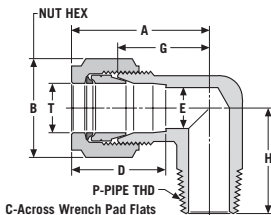

Dimensions — mm

Part Number*		T	P
NPT Threads	RT Threads	Tube O.D.	Male NPT Size
3LM2[]ME	3LM2[]MC	3	1/8
3LM4[]ME	3LM4[]MC	3	1/4
4LM2[]ME	4LM2[]MC	4	1/8
4LM4[]ME	4LM4[]MC	4	1/4
6LM2[]ME	6LM2[]MC	6	1/8
6LM4[]ME	6LM4[]MC	6	1/4
6LM6[]ME	6LM6[]MC	6	3/8
6LM8[]ME	6LM8[]MC	6	1/2
8LM2[]ME	8LM2[]MC	8	1/8
8LM4[]ME	8LM4[]MC	8	1/4
8LM6[]ME	8LM6[]MC	8	3/8
8LM8[]ME	8LM8[]MC	8	1/2
10LM2[]ME	10LM2[]MC	10	1/8
10LM4[]ME	10LM4[]MC	10	1/4
10LM6[]ME	10LM6[]MC	10	3/8
10LM8[]ME	10LM8[]MC	10	1/2
12LM4[]ME	12LM4[]MC	12	1/4
12LM6[]ME	12LM6[]MC	12	3/8
12LM8[]ME	12LM8[]MC	12	1/2
12LM12[]ME	12LM12[]MC	12	3/4
14LM6[]ME	14LM6[]MC	14	3/8
14LM8[]ME	14LM8[]MC	14	1/2
15LM8[]ME	15LM8[]MC	15	1/2
16LM6[]ME	16LM6[]MC	16	3/8
16LM8[]ME	16LM8[]MC	16	1/2
16LM12[]ME	16LM12[]MC	16	3/4
18LM8[]ME	18LM8[]MC	18	1/2
18LM12[]ME	18LM12[]MC	18	3/4
20LM8[]ME	20LM8[]MC	20	1/2
20LM12[]ME	20LM12[]MC	20	3/4
22LM8[]ME	22LM8[]MC	22	1/2
22LM12[]ME	22LM12[]MC	22	3/4
22LM16[]ME	22LM16[]MC	22	1
25LM12[]ME	25LM12[]MC	25	3/4
25LM16[]ME	25LM16[]MC	25	1

* [] see page 59-60 for material specifications.

Male Elbow: LM/EC

connects fractional tube with RT tapered threads



Dimensions — inches

Part Number*	T Tube O.D.	P Pipe Thd.
4LM2[]EC	1/4	1/8
4LM4[]EC	1/4	1/4
8LM4[]EC	1/2	1/4
8LM6[]EC	1/2	3/8
8LM8[]EC	1/2	1/2

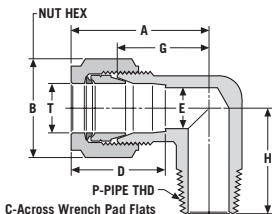

Male Elbow: LM/MA

connects metric with RS parallel threads

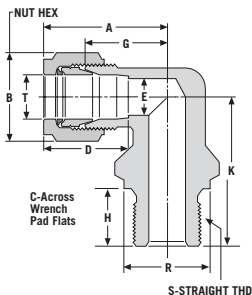
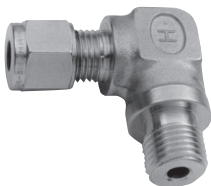

Dimensions — mm

Part Number*	T Tube O.D.	S Straight Thd.
6LM4[]MA	6	1/4
8LM4[]MA	8	1/4
10LM4[]MA	10	1/4
10LM8[]MA	10	1/2
12LM4[]MA	12	1/4
12LM8[]MA	12	1/2
16LM6[]MA	16	3/8
16LM8[]MA	16	1/2
22LM12[]MA	22	3/4

NOTE: RP parallel thread ends are typically used with a gasket having a bonded elastomer seal. RP-type gaskets may also be used.

* [] see page 59-60 for material specifications.

Male Elbow: LM/MB

connects **metric** with RP parallel threads

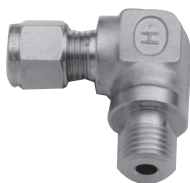
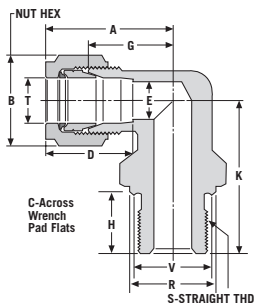

Dimensions — mm

Part Number*	T	S
	Tube O.D.	Straight Thd.
6LM2[]MB	6	1/8
6LM4[]MB	6	1/4

RP parallel thread ends are typically used with a flat gasket to seal.

45° Male Elbow: LMF

connects **fractional** tube to female NPT thread

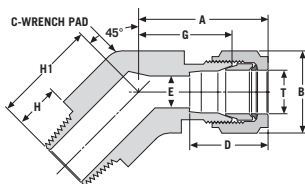

Dimensions — inches

Part Number*	T	P
	Tube O.D.	Pipe Thd.
4LMF2[]	1/4	1/8
4LMF4[]	1/4	1/4
6LMF2[]	3/8	1/8
6LMF4[]	3/8	1/4
6LMF6[]	3/8	3/8
8LMF6[]	1/2	3/8
8LMF8[]	1/2	1/2

* [] see page 59-60 for material specifications.

45° Male Elbow, SAE, Positionable: LMFS

connects fractional tube to SAE straight thread boss

Dimensions — inches



Part Number*	T	S
4LMFS4[]	1/4	7/16-20
6LMFS6[]	3/8	9/16-18
8LMFS8[]	1/2	3/4-16
12LMFS12[]	3/4	1 1/16-12
16LMFS16[]	1	1 5/16-12

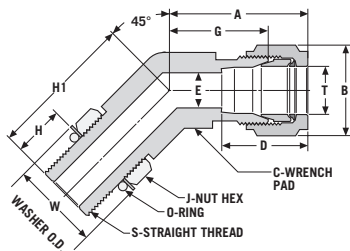

Male Elbow, SAE, Positionable: LMS

connects fractional tube to SAE straight thread boss

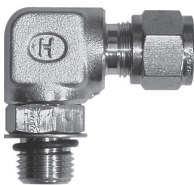

Dimensions — inches

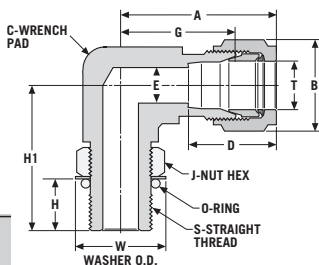

Part Number*	T	S
4LMS4[]	1/4	7/16-20
4LMS6[]	1/4	9/16-18
6LMS6[]	3/8	9/16-18
6LMS8[]	3/8	3/4-16
8LMS8[]	1/2	3/4-16
12LMS12[]	3/4	1 1/16-12
16LMS16[]	1	1 5/16-12
20LMS20[]	1 1/4	1 5/8-12
24LMS24[]	1 1/2	1 7/8-12

* [] see page 59-60 for material specifications.

Male Branch: TTM

connects **fractional** tube to female NPT threads

Dimensions — inches

Part Number*	T Tube O.D.	P Male Pipe Size
1TTM1[]	1/16	1/16
2TTM2[]	1/8	1/8
2TTM4[]	1/8	1/4
3TTM2[]	3/16	1/8
4TTM2[]	1/4	1/8
4TTM4[]	1/4	1/4
6TTM4[]	3/8	1/4
6TTM6[]	3/8	3/8
6TTM8[]	3/8	1/2
8TTM4[]	1/2	1/4
8TTM6[]	1/2	3/8
8TTM8[]	1/2	1/2
10TTM6[]	5/8	3/8
10TTM8[]	5/8	1/2
12TTM8[]	3/4	1/2
12TTM12[]	3/4	3/4
16TTM12[]	1	3/4
16TTM16[]	1	1



Metric fitting shown

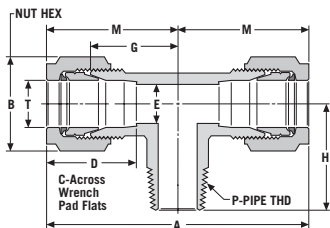

Male Branch Tee: TTM/ME

connects **metric** tube to female NPT threads

Dimensions — mm

Part Number*	T Tube O.D.	P Male Pipe Thd.
3TTM2[]ME	3	1/8
4TTM2[]ME	4	1/8
4TTM4[]ME	4	1/4
6TTM2[]ME	6	1/8
6TTM4[]ME	6	1/4
6TTM6[]ME	6	3/8
8TTM2[]ME	8	1/8
8TTM4[]ME	8	1/4
8TTM6[]ME	8	3/8
8TTM8[]ME	8	1/2
10TTM2[]ME	10	1/8
10TTM4[]ME	10	1/4
10TTM6[]ME	10	3/8
10TTM8[]ME	10	1/2
12TTM4[]ME	12	1/4
12TTM6[]ME	12	3/8
12TTM8[]ME	12	1/2



Metric fitting shown

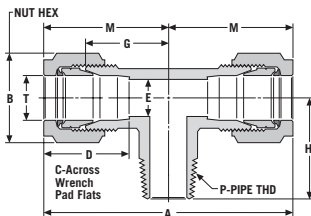

* [] see page 59-60 for material specifications.

Male Run Tee: TMT/ME

connects **metric** tube
to female NPT threads

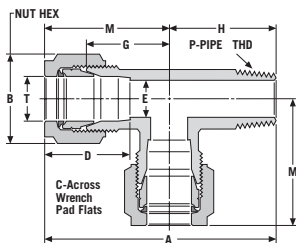

Dimensions — mm

Part Number*	T Tube O.D.	S Pipe Thd.
3TMT2[]ME	3	1/8
6TMT2[]ME	6	1/8
6TMT4[]ME	6	1/4
6TMT6[]ME	6	3/8
6TMT8[]ME	6	1/2
8TMT2[]ME	8	1/8
8TMT4[]ME	8	1/4
10TMT2[]ME	10	1/8
10TMT4[]ME	10	1/4
10TMT6[]ME	10	3/8
12TMT4[]ME	12	1/4
12TMT8[]ME	12	1/2

Male Run Tee: TMT

connects **fractional** tube
to female NPT thread

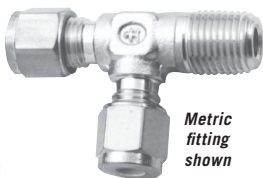

Metric fitting shown

Dimensions — inches

Part Number*	T Tube O.D.	P Male NPT Size
1TMT1[]	1/16	1/16
2TMT2[]	1/8	1/8
3TMT2[]	3/16	1/8
4TMT2[]	1/4	1/8
4TMT4[]	1/4	1/4
6TMT4[]	3/8	1/4
6TMT6[]	3/8	3/8
8TMT6[]	1/2	3/8
8TMT8[]	1/2	1/2
10TMT8[]	5/8	1/2
12TMT12[]	3/4	3/4
16TMT12[]	1	3/4
16TMT16[]	1	1

Tee, SAE Run, Positionable: TST

connects **fractional** tube to SAE straight thread boss



Dimensions — inches

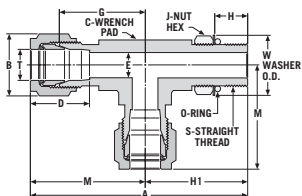

Part Number*	T Tube O.D.	S
4TST4[]	1/4	7/16-20
6TST6[]	3/8	9/16-18
8TST8[]	1/2	3/4-16
12TST12[]	3/4	1 1/16-12
16TST16[]	1	1 5/16-12

* [] see page 59-60 for material specifications.

Tee, SAE Branch, Positionable: TTS

connects **fractional** tube to SAE straight thread boss

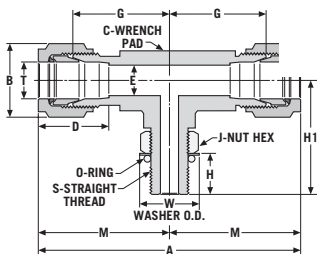

Dimensions — inches

T			
Part Number*	Tube O.D.	S	
4TTS4[]	1/4	7/16-20	
6TTS6[]	3/8	9/16-18	
8TTS8[]	1/2	3/4-16	
12TTS12[]	3/4	1 1/16-12	
16TTS16[]	1	5/16-12	

Female Connector: CF

connects **fractional** tube to male NPT threads

Dimensions — inches

Part Number*	T	P
	Tube O.D.	Female NPT Size
1CF1[]	1/16	1/16
1CF2[]	1/16	1/8
2CF2[]	1/8	1/8
2CF4[]	1/8	1/4
3CF2[]	3/16	1/8
3CF4[]	3/16	1/4
4CF2[]	1/4	1/8
4CF4[]	1/4	1/4
4CF6[]	1/4	3/8
4CF8[]	1/4	1/2
6CF2[]	3/8	1/8
6CF4[]	3/8	1/4
6CF6[]	3/8	3/8
6CF8[]	3/8	1/2
6CF12[]	3/8	3/4
8CF4[]	1/2	1/4
8CF6[]	1/2	3/8
8CF8[]	1/2	1/2
8CF12[]	1/2	3/4
8CF16[]	1/2	1
10CF6[]	5/8	3/8
10CF8[]	5/8	1/2
12CF8[]	3/4	1/2
12CF12[]	3/4	3/4
16CF12[]	1	3/4
16CF16[]	1	1
20CF20[]	1 1/4	1 1/4
24CF24[]	1 1/2	1 1/2
32CF32[]	2	2



Metric fitting shown

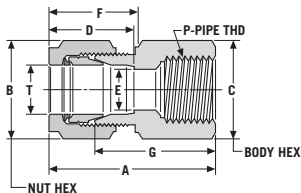

* [] see page 59-60 for material specifications.

Female Connector: CF/ME

connects **metric** tube to male NPT threads



Metric fitting shown

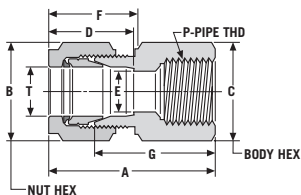

Dimensions — mm

Part Number*	T Tube O.D.	P Female NPT Size
3CF2[]ME	3	1/8
3CF4[]ME	3	1/4
6CF2[]ME	6	1/8
6CF4[]ME	6	1/4
6CF6[]ME	6	3/8
6CF8[]ME	6	1/2
8CF2[]ME	8	1/8
8CF4[]ME	8	1/4
8CF6[]ME	8	3/8
8CF8[]ME	8	1/2
10CF2[]ME	10	1/8
10CF4[]ME	10	1/4
10CF6[]ME	10	3/8
10CF8[]ME	10	1/2
12CF4[]ME	12	1/4
12CF6[]ME	12	3/8
12CF8[]ME	12	1/2
12CF12[]ME	12	3/4
14CF4[]ME	14	1/4
14CF8[]ME	14	1/2
15CF8[]ME	15	1/2
16CF8[]ME	16	1/2
16CF12[]ME	16	3/4
18CF8[]ME	18	1/2
18CF12[]ME	18	3/4
20CF8[]ME	20	1/2
20CF12[]ME	20	3/4
22CF8[]ME	22	1/2
22CF12[]ME	22	3/4
22CF16[]ME	22	1
25CF8[]ME	25	1/2
25CF12[]ME	25	3/4
25CF16[]ME	25	1

Female Connector: CF/EZ

connects **fractional** tube with RG parallel threads



Fractional fitting shown

Dimensions — inches

Part Number*	T Tube O.D.	S Thd. Size
2CF2[]EZ	1/8	1/8
2CF4[]EZ	1/8	1/4
4CF[]EZ	1/4	1/4
4CF8[]EZ	1/4	1/2
6CF4[]EZ	3/8	1/4
6CF8[]EZ	3/8	1/2
8CF4[]EZ	1/2	1/4
8CF8[]EZ	1/2	1/2

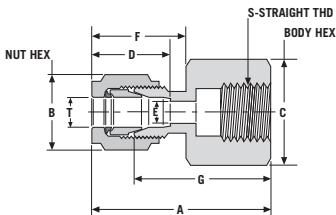

NOTE: RG female thread ends require a gasket inserted into the flat bottom of the thread. The male end, when assembled, exerts pressure on the gasket creating a seal.

* [] see page 59-60 for material specifications.

Female Connector: CF/MZ

connects **metric** tube with RG parallel threads

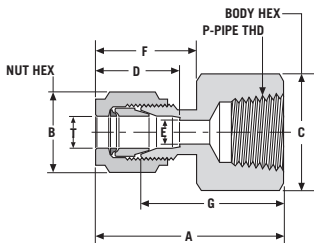

Fractional fitting shown

Dimensions — mm

Part Number*	T Tube O.D.	S Thd. Size
3CF4[]MZ	3	1/4
6CF4[]MZ	6	1/4
6CF8[]MZ	6	1/2
8CF4[]MZ	8	1/4
8CF8[]MZ	8	1/2
10CF4[]MZ	10	1/4
10CF8[]MZ	10	1/2
12CF4[]MZ	12	1/4
12CF8[]MZ	12	1/2
14CF8[]MZ	14	1/2
16CF8[]MZ	16	1/2
18CF8[]MZ	18	1/2
20CF8[]MZ	20	1/2
22CF8[]MZ	22	1/2
25CF8[]MZ	25	1/2

Female Connector: CF/EC

connects **fractional** tube with RT tapered threads

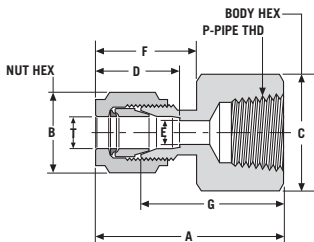

Fractional fitting shown

Dimensions — inches

Part Number*	T Tube O.D.	P Pipe Thd.
4CF2[]EC	1/4	1/8
4CF4[]EC	1/4	1/4
4CF6[]EC	1/4	3/8
4CF8[]EC	1/4	1/2
6CF4[]EC	3/8	1/4
6CF6[]EC	3/8	3/8
6CF8[]EC	3/8	1/2
8CF4[]EC	1/2	1/4
8CF6[]EC	1/2	3/8
8CF8[]EC	1/2	1/2
10CF8[]EC	5/8	1/2

* [] see page 59-60 for material specifications.

Female Connector: CF/MC

connects **metric** tube with RT tapered threads

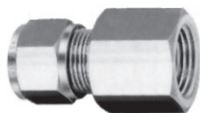

Fractional fitting shown

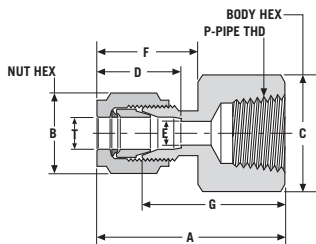

Dimensions — mm

Part Number* RT Threads	T Tube O.D.	P Pipe Thd.
3CF2[]MC	3	1/8
3CF4[]MC	3	1/4
6CF2[]MC	6	1/8
6CF4[]MC	6	1/4
6CF6[]MC	6	3/8
6CF8[]MC	6	1/2
8CF2[]MC	8	1/8
8CF4[]MC	8	1/4
8CF6[]MC	8	3/8
8CF8[]MC	8	1/2
10CF2[]MC	10	1/8
10CF4[]MC	10	1/4
10CF6[]MC	10	3/8
10CF8[]MC	10	1/2
12CF4[]MC	12	1/4
12CF6[]MC	12	3/8
12CF8[]MC	12	1/2
12CF12[]MC	12	3/4
14CF4[]MC	14	1/4
14CF8[]MC	14	1/2
15CF8[]MC	15	1/2
16CF8[]MC	16	1/2
16CF12[]MC	16	3/4
18CF8[]MC	18	1/2
18CF12[]MC	18	3/4
20CF8[]MC	20	1/2
20CF12[]MC	20	3/4
22CF8[]MC	22	1/2
22CF12[]MC	22	3/4
22CF16[]MC	22	1
25CF8[]MC	25	1/2
25CF12[]MC	25	3/4
25CF16[]MC	25	1

Bulkhead Connector, Female: BCF

connects **fractional** tube to male NPT thread



Metric fitting shown

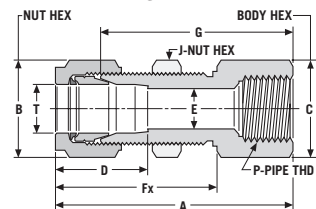

Dimensions — inches

Part Number*	T Tube O.D.	P Male NPT Size
2BCF2[]	1/8	1/8
4BCF2[]	1/4	1/8
4BCF4[]	1/4	1/4
6BCF2[]	3/8	1/8
6BCF4[]	3/8	1/4
6BCF6[]	3/8	3/8
8BCF4[]	1/2	1/4
8BCF6[]	1/2	3/8
8BCF8[]	1/2	1/2
10BCF8[]	5/8	1/2

* [] see page 59-60 for material specifications.

Bulkhead Connector, Female: BCF/ME

connects metric tube to male NPT threads

Dimensions — mm

Part Number*	T Tube O.D.	P	
		Male NPT Size	
3BCF2[]ME	3	1/8	
6BCF2[]ME	6	1/8	
6BCF4[]ME	6	1/4	
8BCF4[]ME	8	1/4	
10BCF4[]ME	10	1/4	
12BCF6[]ME	12	3/8	
12BCF8[]ME	12	1/2	
14BCF8[]ME	14	1/2	
16BCF8[]ME	16	1/2	
18BCF8[]ME	18	1/2	
22BCF8[]ME	22	1/2	
25BCF8[]ME	25	1/2	



Metric fitting shown

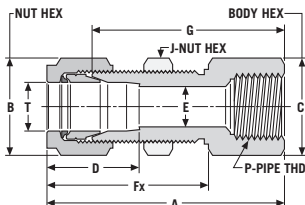

Female Elbow: LF

connects fractional tube to male NPT threads

Dimensions — inches

Part Number*	T Tube O.D.	P	
		Pipe Size	
1LF1[]	1/16	1/16	
1LF2[]	1/16	1/8	
2LF2[]	1/8	1/8	
2LF4[]	1/8	1/4	
3LF2[]	3/16	1/8	
4LF2[]	1/4	1/8	
4LF4[]	1/4	1/4	
4LF6[]	1/4	3/8	
4LF8[]	1/4	1/2	
6LF2[]	3/8	1/8	
6LF4[]	3/8	1/4	
6LF6[]	3/8	3/8	
6LF8[]	3/8	1/2	
8LF4[]	1/2	1/4	
8LF6[]	1/2	3/8	
8LF8[]	1/2	1/2	
8LF12[]	1/2	3/4	
10LF6[]	5/8	3/8	
10LF8[]	5/8	1/2	
12LF8[]	3/4	1/2	
12LF12[]	3/4	3/4	
16LF12[]	1	3/4	
16LF16[]	1	1	

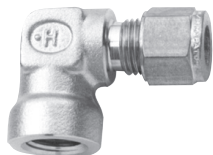

Metric fitting shown

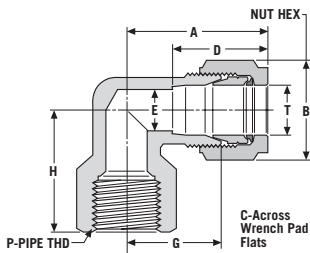

* [] see page 59-60 for material specifications.

Female Elbow: LF/ME, LF/MC

connects **metric** tube to male NPT or RT tapered threads

Dimensions — mm

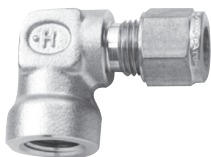

Metric fitting shown

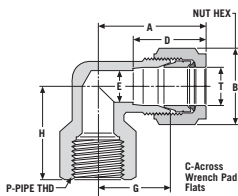

Part Number*		T	P
NPT Threads	RT Threads	Tube O.D.	Pipe Size
3LF2[]ME	3LF2[]MC	3	1/8
3LF4[]ME	3LF4[]MC	3	1/4
4LF4[]ME	4LF4[]MC	4	1/4
6LF2[]ME	6LF2[]MC	6	1/8
6LF4[]ME	6LF4[]MC	6	1/4
6LF6[]ME	6LF6[]MC	6	3/8
6LF8[]ME	6LF8[]MC	6	1/2
8LF2[]ME	8LF2[]MC	8	1/8
8LF4[]ME	8LF4[]MC	8	1/4
8LF6[]ME	8LF6[]MC	8	3/8
10LF2[]ME	10LF2[]MC	10	1/8
10LF4[]ME	10LF4[]MC	10	1/4
10LF6[]ME	10LF6[]MC	10	3/8
10LF8[]ME	10LF8[]MC	10	1/2
12LF4[]ME	12LF4[]MC	12	1/4
12LF6[]ME	12LF6[]MC	12	3/8
12LF8[]ME	12LF8[]MC	12	1/2
14LF8[]ME	14LF8[]MC	14	1/2
16LF8[]ME	16LF8[]MC	16	1/2
18LF8[]ME	18LF8[]MC	18	1/2
18LF12[]ME	18LF12[]MC	18	3/4
22LF8[]ME	22LF8[]MC	22	1/2
22LF12[]ME	22LF12[]MC	22	3/4
25LF12[]ME	25LF12[]MC	25	3/4
25LF16[]ME	25LF16[]MC	25	1

Female Run Tee: TFT

connects **fractional** tube to male NPT threads

Dimensions — inches



Fractional fitting shown

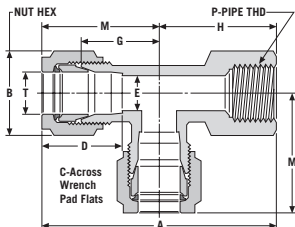

Part Number*	T Tube O.D.	P Pipe Size
1TFT1[]	1/16	1/16
2TFT2[]	1/8	1/8
3TFT2[]	3/16	1/8
4TFT2[]	1/4	1/8
4TFT4[]	1/4	1/4
6TFT4[]	3/8	1/4
6TFT6[]	3/8	3/8
8TFT4[]	1/2	1/4
8TFT6[]	1/2	3/8
8TFT8[]	1/2	1/2
10TFT8[]	5/8	1/2
12TFT8[]	3/4	1/2
12TFT12[]	3/4	3/4
16TFT12[]	1	3/4
16TFT16[]	1	1

* [] see page 59-60 for material specifications.

Female Run Tee: TFT/ME

connects metric tube to male NPT threads

Dimensions — mm

Part Number*	T Tube O.D.	S Pipe Thd.
3TFT2[]ME	3	1/8
6TFT2[]ME	6	1/8
6TFT4[]ME	6	1/4
6TFT8[]ME	6	1/2
10TFT2[]ME	10	1/8
10TFT4[]ME	10	1/4
10TFT6[]ME	10	3/8
10TFT8[]ME	10	1/2
12TFT4[]ME	12	1/4
12TFT8[]ME	12	1/2



Fractional fitting shown

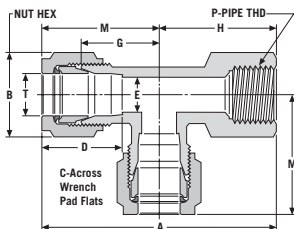

Female Branch Tee: TTF

connects fractional tube to male NPT threads

Dimensions — inches

Part Number*	T Tube O.D.	P Pipe Size
1TTF1[]	1/16	1/16
2TTF2[]	1/8	1/8
3TTF2[]	3/16	1/8
4TTF2[]	1/4	1/8
4TTF4[]	1/4	1/4
6TTF4[]	3/8	1/4
6TTF6[]	3/8	3/8
6TTF8[]	3/8	1/2
8TTF4[]	1/2	1/4
8TTF6[]	1/2	3/8
8TTF8[]	1/2	1/2
10TTF8[]	5/8	1/2
12TTF8[]	3/4	1/2
12TTF12[]	3/4	3/4
16TTF12[]	1	3/4
16TTF16[]	1	1



Fractional fitting shown

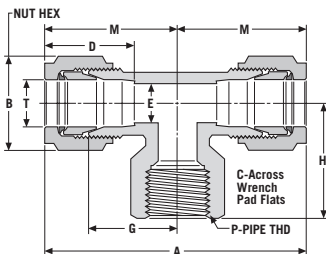

* [] see page 59-60 for material specifications.

Female Branch Tee: TTF/ME

connects **metric** tube to male NPT threads



Fractional fitting shown

Dimensions — mm

Part Number*	T Tube O.D.	P Pipe Thd.
3TTF2[]ME	3	1/8
4TTF2[]ME	4	1/8
4TTF4[]ME	4	1/4
6TTF2[]ME	6	1/8
6TTF4[]ME	6	1/4
6TTF6[]ME	6	3/8
6TTF8[]ME	6	1/2
8TTF2[]ME	8	1/8
8TTF4[]ME	8	1/4
10TTF2[]ME	10	1/8
10TTF4[]ME	10	1/4
10TTF6[]ME	10	3/8
10TTF8[]ME	10	1/2
12TTF4[]ME	12	1/4
12TTF8[]ME	12	1/2
16TTF8[]ME	16	1/2

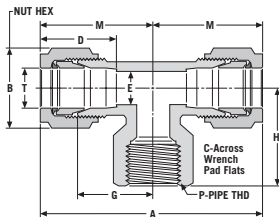

Union: U/MM

connects **metric** tubes

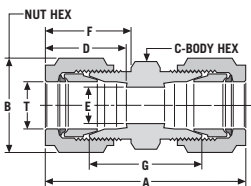

Dimensions — mm

Part Number*	T Tube O.D.
3U[]MM	3
4U[]MM	4
6U[]MM	6
8U[]MM	8
10U[]MM	10
12U[]MM	12
14U[]MM	14
15U[]MM	15
16U[]MM	16
18U[]MM	18
20U[]MM	20
22U[]MM	22
25U[]MM	25
30U[]MM	30
32U[]MM	32
38U[]MM	38

Union: U

connects **fractional** tubes



Fractional fitting shown

Dimensions — inches

Part Number*	T Tube O.D.
1U[]	1/16
2U[]	1/8
3U[]	3/16
4U[]	1/4
6U[]	3/8
8U[]	1/2
10U[]	5/8
12U[]	3/4
16U[]	1
20U[]	1 1/4
24U[]	1 1/2
32U[]	2

* [] see page 59-60 for material specifications.

Reducing Union: RU connects fractional tubes

Dimensions — inches

Part Number*	T Tube O.D.	Tx Tube O.D.
2RU1[]	1/8	1/16
3RU1[]	3/16	1/16
3RU2[]	3/16	1/8
4RU1[]	1/4	1/16
4RU2[]	1/4	1/8
4RU3[]	1/4	3/16
6RU1[]	3/8	1/16
6RU2[]	3/8	1/8
6RU4[]	3/8	1/4
8RU2[]	1/2	1/8
8RU4[]	1/2	1/4
8RU6[]	1/2	3/8
10RU6[]	5/8	3/8
10RU8[]	5/8	1/2
12RU4[]	3/4	1/4
12RU6[]	3/4	3/8
12RU8[]	3/4	1/2
12RU10[]	3/4	5/8
16RU8[]	1	1/2
16RU12[]	1	3/4
16RU14[]	1	7/8
32RU24[]	2	1 1/2

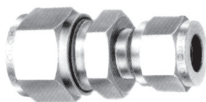

Fractional fitting shown

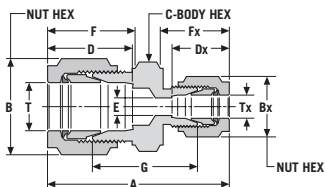

Reducing Union: RU/MM connects metric tubes

Dimensions — mm

Part Number*	T Tube O.D.	Tx Tube O.D.
4RU3[]MM	4	3
6RU3[]MM	6	3
6RU4[]MM	6	4
8RU4[]MM	8	4
8RU6[]MM	8	6
10RU6[]MM	10	6
10RU8[]MM	10	8
12RU6[]MM	12	6
12RU8[]MM	12	8
12RU10[]MM	12	10
14RU8[]MM	14	8
14RU10[]MM	14	10
14RU12[]MM	14	12
16RU10[]MM	16	10
16RU12[]MM	16	12
18RU12[]MM	18	12
18RU16[]MM	18	16
22RU12[]MM	22	12
22RU18[]MM	22	18
25RU12[]MM	25	12
25RU18[]MM	25	18

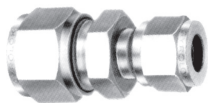

Fractional fitting shown

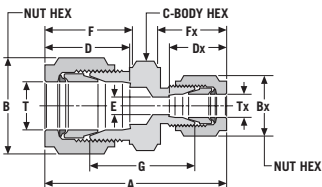

* [] see page 59-60 for material specifications.

Reducing Union: RU/ME

connects **metric** tubes to fractional tubes

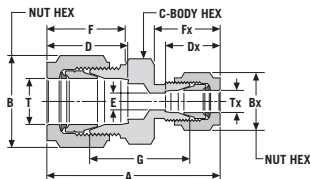
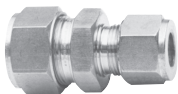

* [] see page 59-60 for material specifications.

Dimensions — mm

Part Number*	T	Tx	A
	Tube O.D.	Tube O.D.	
3RU1[]ME	3	1/16	36.1
3RU2[]ME	3	1/8	38.0
3RU4[]ME	3	1/4	42.5
4RU2[]ME	4	1/8	40.6
4RU4[]ME	4	1/4	43.0
6RU1[]ME	6	1/16	37.5
6RU2[]ME	6	1/8	43.2
6RU4[]ME	6	1/4	44.7
6RU8[]ME	6	1/2	49.7
8RU2[]ME	8	1/8	42.9
8RU3[]ME	8	3/16	43.2
8RU4[]ME	8	1/4	44.8
8RU6[]ME	8	3/8	42.7
8RU8[]ME	8	1/2	50.9
8RU10[]ME	8	5/8	50.1
10RU2[]ME	10	1/8	43.5
10RU4[]ME	10	1/4	46.8
10RU6[]ME	10	3/8	46.8
10RU8[]ME	10	1/2	50.3
10RU10[]ME	10	5/8	50.9
12RU4[]ME	12	1/4	49.5
12RU6[]ME	12	3/8	50.1
12RU8[]ME	12	1/2	54.9
16RU10[]ME	16	5/8	55.0
16RU12[]ME	16	3/4	57.5
18RU12[]ME	18	3/4	57.0

Bulkhead Union: BU

connects **fractional** tubes



Fractional fitting shown

Dimensions — inches

Part Number*	T
	Tube O.D.
1BU[]	1/16
2BU[]	1/8
3BU[]	3/16
4BU[]	1/4
6BU[]	3/8
8BU[]	1/2
10BU[]	5/8
12BU[]	3/4
16BU[]	1
24BU[]	1 1/2
32BU[]	2

Bulkhead Union: BU/MM

connects **metric** tubes

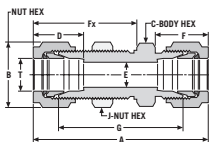

Dimensions — mm

Part Number*	T
	Tube O.D.
3BU[]MM	3
4BU[]MM	4
6BU[]MM	6
8BU[]MM	8
10BU[]MM	10
12BU[]MM	12
14BU[]MM	14
15BU[]MM	15
16BU[]MM	16
18BU[]MM	18
20BU[]MM	20
22BU[]MM	22
25BU[]MM	25

Union Elbow: LU

connects fractional tubes



Metric fitting shown

Dimensions — inches

Part Number*	T Tube O.D.
1LU[]	1/16
2LU[]	1/8
3LU[]	3/16
4LU[]	1/4
6LU[]	3/8
8LU[]	1/2
10LU[]	5/8
12LU[]	3/4
16LU[]	1
20LU[]	1 1/4
24LU[]	1 1/2
32LU32[]	2

Union Elbow: LU/MM

connects metric tubes

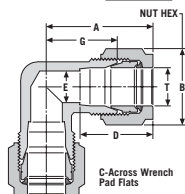

Dimensions — mm

Part Number*	T Tube O.D.
3LU[]MM	3
4LU[]MM	4
6LU[]MM	6
8LU[]MM	8
10LU[]MM	10
12LU[]MM	12
14LU[]MM	14
15LU[]MM	15
16LU[]MM	16
18LU[]MM	18
20LU[]MM	20
22LU[]MM	22
25LU[]MM	25
30LU[]MM	30
32LU[]MM	32
38LU[]MM	38

Union Tee: TTT connects fractional tubes

Dimensions — inches

Part Number*	T Tube O.D.
1TTT[]	1/16
2TTT[]	1/8
3TTT[]	3/16
4TTT[]	1/4
6TTT[]	3/8
8TTT[]	1/2
10TTT[]	5/8
12TTT[]	3/4
16TTT[]	1
20TTT[]	1 1/4
24TTT[]	1 1/2
32TTT[]	2



Metric fitting shown

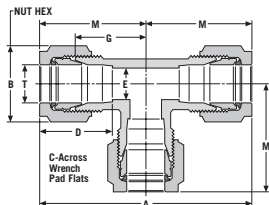

* [] see page 59-60 for material specifications.

Union Tee: TTT/MM connects metric tubes



Metric fitting shown

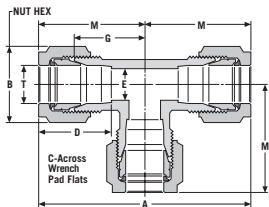

Dimensions — mm

Part Number*	T Tube O.D.
3TTT [MM]	3
4TTT [MM]	4
6TTT [MM]	6
8TTT [MM]	8
10TTT [MM]	10
12TTT [MM]	12
14TTT [MM]	14
15TTT [MM]	15
16TTT [MM]	16
18TTT [MM]	18
20TTT [MM]	20
22TTT [MM]	22
25TTT [MM]	25
30TTT [MM]	30
32TTT [MM]	32
38TTT [MM]	38

Reducing Run Tee: TTT_B connects fractional tubes



Dimensions — inches

Part Number*	T Tube O.D.	U Run	V Branch
10TTT8BR6 []	5/8	1/2	3/8
12TTT10BR6 []	3/4	5/8	3/8
12TTT10BR8 []	3/4	5/8	1/2
16TTT10BR6 []	1	5/8	3/8
16TTT10BR8 []	1	5/8	1/2
16TTT12BR6 []	1	3/4	3/8

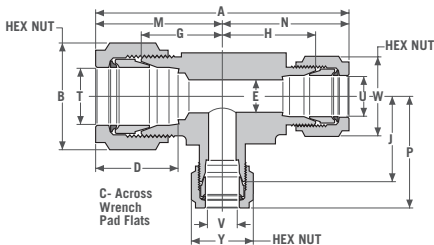

* [] see page 59-60 for material specifications.

Reducing Branch Tee: TTTB

connects **fractional** tubes

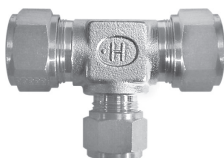
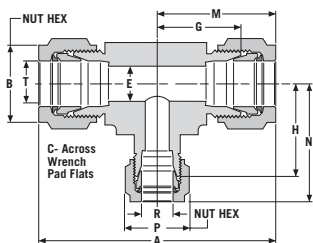

Fractional fitting shown

Dimensions — inches

Part Number*	T	
	Tube O.D.	R Branch
6TTTB8[]	3/8	1/2
8TTTB6[]	1/2	3/8
10TTTB6[]	5/8	3/8
10TTTB8[]	5/8	1/2
12TTTB6[]	3/4	3/8
12TTTB8[]	3/4	1/2
16TTTB6[]	1	3/8
16TTTB8[]	1	1/2
20TTTB16[]	1 1/4	1
24TTTB16[]	1 1/2	1
32TTTB16[]	2	1
32TTTB24[]	2	1 1/2

Reducing Union Tee: TTTB/MM

connects **metric** tubes

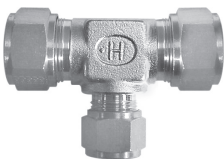
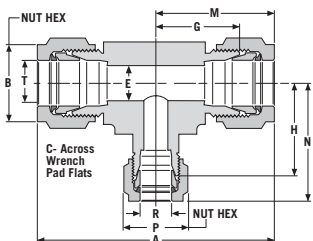

Fractional fitting shown

Dimensions — mm

Part Number*	T	
	Tube O.D.	R Branch
32TTTB25316MM	32	25

* [] see page 59-60 for material specifications.

Union Cross: C connects fractional tubes



Fractional fitting shown

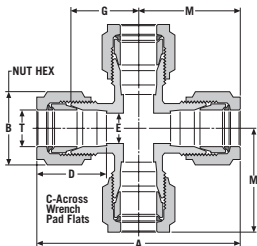

Dimensions — inches

Part Number*	T	
	Tube O.D.	A
1C []	1/16	1.56
2C []	1/8	1.94
3C []	3/16	2
4C []	1/4	2.14
6C []	3/8	2.38
8C []	1/2	2.88
10C []	5/8	2.94
12C []	3/4	3.19
16C []	1	3.75

Union Cross: C/MM connects metric tubes



Fractional fitting shown

Dimensions — mm

Part Number*	T	
	Tube O.D.	
3C []MM	3	
4C []MM	4	
6C []MM	6	
8C []MM	8	
10C []MM	10	
12C []MM	12	
14C []MM	14	
16C []MM	16	
18C []MM	18	
20C []MM	20	
22C []MM	22	
25C []MM	25	

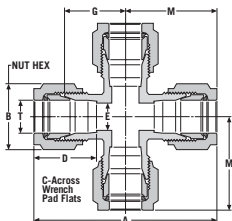

* [] see page 59-60 for material specifications.

AN Fittings

Union, AN: UAN

connects fractional tube to flared tube

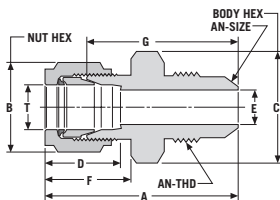

Dimensions — inches

Part Number*	T		
	Tube O.D.	AN Size	AN Thread
1UAN4[]	1/16	1/4	7/16-20
2UAN2[]	1/8	1/8	5/16-24
2UAN4[]	1/8	1/4	7/16-20
3UAN3[]	3/16	3/16	3/8-24
4UAN4[]	1/4	1/4	7/16-20
6UAN4[]	3/8	1/4	7/16-20
6UAN6[]	3/8	3/8	9/16-18
8UAN8[]	1/2	1/2	3/4-16
10UAN10[]	5/8	5/8	7/8-14
12UAN12[]	3/4	3/4	1 1/16-12
16UAN16[]	1	1	1 5/16-12

UAN Application:

GYROLOK® with AND 10056 or MS 33656, 37° flare connections for use with flared tubing.

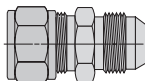

UAN

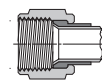

Mating Part

* [] see page 59-60 for material specifications.

Union, AN O-ring: UANO

connects fractional
tube to flared tube

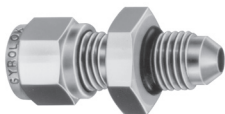

Dimensions — inches

Part Number*	T		
	Tube O.D.	AN Size	AN Thread
1UAN4[]	1/16	1/4	7/16-20
2UAN2[]	1/8	1/8	5/16-24
2UAN4[]	1/8	1/4	7/16-20
3UAN3[]	3/16	3/16	3/8-24
4UAN4[]	1/4	1/4	7/16-20
6UAN4[]	3/8	1/4	7/16-20
6UAN6[]	3/8	3/8	9/16-18
8UAN8[]	1/2	1/2	3/4-16
10UAN10[]	5/8	5/8	7/8-14
12UAN12[]	3/4	3/4	1 1/16-12
16UAN16[]	1	1	1 5/16-12

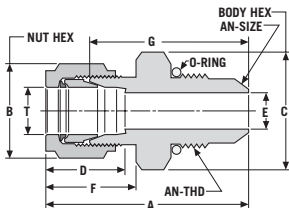

UANO Application:

GYROLOK® with AND 10056 or MS 33656 for gasket sealing with AND 10050 or MS 16142 ports.

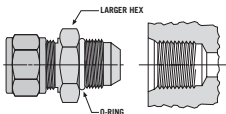

UANO

Mating Part

Bulkhead Union, AN: BUAN

connects fractional
tube to flared tube



Dimensions — inches

Part Number*	T		
	Tube O.D.	AN Size	AN Thread
2BUAN2[]	1/8	1/8	5/16-24
2BUAN4[]	1/8	1/4	7/16-20
3BUAN3[]	3/16	3/16	3/8-24
4BUAN4[]	1/4	1/4	7/16-20
6BUAN4[]	3/8	1/4	7/16-20
6BUAN6[]	3/8	3/8	9/16-18
8BUAN8[]	1/2	1/2	3/4-16
10BUAN10[]	5/8	5/8	7/8-14
12BUAN12[]	3/4	3/4	1 1/16-12
16BUAN16[]	1	1	1 5/16-12

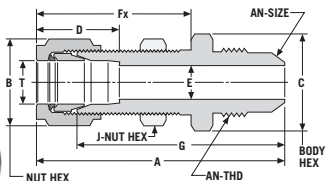

* [] see page 59-60 for material specifications.

BUAN Application:

GYROLOK® bulkhead configuration with AND 10056 or MS 33656, 37° flare connection for use with flared tubing.

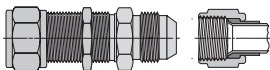

BUAN

Mating Part

Adapter, AN: AAN

connects **fractional** GYROLOK® port to flared tube

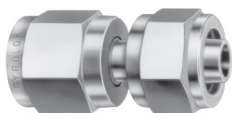
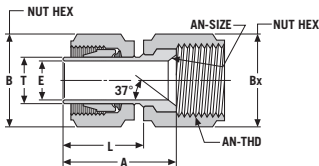

Dimensions — inches

AAN Application:

GYROLOK® tube stub with ferrules pre-set with 37° flare connection for use with AND 10056 or MS 33656 ends.

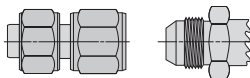

AAN

Mating Part

Note: The tube stub end comes with pre-set GYROLOK® ferrules. To assemble, follow GYROLOK® remake instructions, page 49.

Part Number*	T	AN	AN
	Tube O.D.	Size	Thread
2AAN2[]	1/8	1/8	5/16-24
2AAN4[]	1/8	1/4	7/16-20
3AAN3[]	3/16	3/16	3/8-24
4AAN4[]	1/4	1/4	7/16-20
6AAN6[]	3/8	3/8	9/16-18
8AAN8[]	1/2	1/2	3/4-16
10AAN10[]	5/8	5/8	7/8-14
12AAN12[]	3/4	3/4	1 1/16-12
16AAN16[]	1	1	1 5/16-12

Tube Socket Weld Connector: CW

connects **fractional** tubes

Dimensions — inches

Part Number*	T	Tx
	Tube O.D.	Tube O.D.
2CW2[]	1/8	1/8
3CW3[]	3/16	3/16
4CW4[]	1/4	1/4
4CW6[]	1/4	3/8
6CW6[]	3/8	3/8
8CW6[]	1/2	3/8
8CW8[]	1/2	1/2
10CW10[]	5/8	5/8
12CW12[]	3/4	3/4
16CW16[]	1	1

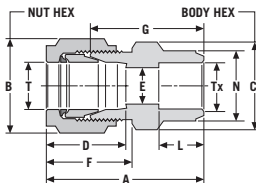

* [] see page 59-60 for material specifications.

Tube Socket Weld Elbow: LW

connects **fractional** tubes

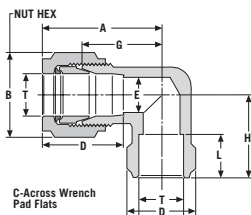

Dimensions — inches

Part Number*	T Tube O.D.
2LW2[]	1/8
3LW3[]	3/16
4LW4[]	1/4
6LW6[]	3/8
8LW8[]	1/2
10LW10[]	5/8
12LW12[]	3/4
16LW16[]	1

* [] see page 59-60 for material specifications.

Butt Weld Connector: CBW

connects fractional tube to pipe

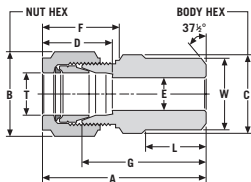

Dimensions — inches

Part Number*	T Tube O.D.	W Butt Weld O.D.	Nom. Pipe Size
2CBW2[]	1/8	.41	1/8
3CBW2[]	3/16	.41	1/8
4CBW2[]	1/4	.41	1/8
4CBW4[]	1/4	.54	1/4
6CBW4[]	3/8	.54	1/4
6CBW6[]	3/8	.68	3/8
6CBW8[]	3/8	.84	1/2
8CBW4[]	1/2	.54	1/4
8CBW6[]	1/2	.68	3/8
8CBW8[]	1/2	.84	1/2
10CBW8[]	5/8	.84	1/2
12CBW12[]	3/4	1.05	3/4
16CBW16[]	1	1.32	1
20CBW20[]	1 1/4	1.66	1 1/4
24CBW24[]	1 1/2	1.90	1 1/2
32CBW32[]	2	2.38	2

Butt Weld Connector: CBW/ME

connects metric tube to pipe



Metric fitting shown

Dimensions — mm

Part Number*	T Tube O.D.	W Butt Weld O.D.	Nom. Pipe Size
3CBW2[]ME	3	10.3	1/8
4CBW2[]ME	4	10.3	1/8
6CBW2[]ME	6	10.3	1/8
6CBW4[]ME	6	13.7	1/4
8CBW2[]ME	8	10.3	1/8
8CBW4[]ME	8	13.7	1/4
8CBW6[]ME	8	17.2	3/8
8CBW8[]ME	8	21.5	1/2
10CBW4[]ME	10	13.7	1/4
10CBW6[]ME	10	17.2	3/8
10CBW8[]ME	10	21.3	1/2
12CBW4[]ME	12	13.7	1/4
12CBW6[]ME	12	17.2	3/8
12CBW8[]ME	12	21.3	1/2
12CBW12[]ME	12	26.7	3/4
14CBW8[]ME	14	21.3	1/2
16CBW8[]ME	16	21.3	1/2
18CBW8[]ME	18	21.3	1/2
22CBW16[]ME	22	33.4	1
25CBW16[]ME	25	33.4	1

* [] see page 59-60 for material specifications.

Butt Weld Elbow: LBW

connects **fractional** tube to pipe



Metric fitting shown

Dimensions — inches

Part Number*	T Tube O.D.	W Butt Weld O.D.	Nom. Pipe Size
2LBW2[]	1/8	.41	1/8
3LBW2[]	3/16	.41	1/8
4LBW2[]	1/4	.41	1/8
4LBW4[]	1/4	.54	1/4
6LBW4[]	3/8	.54	1/4
8LBW6[]	1/2	.68	3/8
8LBW8[]	1/2	.84	1/2
10LBW8[]	5/8	.84	1/2
12LBW12[]	3/4	1.05	3/4
16LBW12[]	1	1.05	3/4
16LBW16[]	1	1.32	1

Butt Weld Elbow: LBW/ME

connects **metric** to pipe

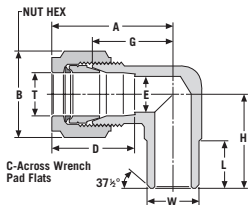

Dimensions — mm

Part Number*	T Tube O.D.	W Butt Weld O.D.	Nom. Pipe Size
3LBW2[]ME	3	10.3	1/8
6LBW2[]ME	6	10.3	1/8
6LBW4[]ME	6	13.7	1/4
12LBW12[]ME	12	26.7	3/4
16LBW8[]ME	16	21.3	1/2
18LBW8[]ME	18	21.3	1/2

* [] see page 59-60 for material specifications.

Reducer: R connects fractional tube to fractional port

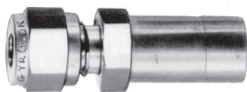
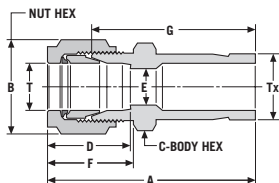

Fractional fitting shown

Dimensions — inches

Part Number*	T Tube O.D.	Tx Tube O.D.
1R2[]	1/16	1/8
1R4[]	1/16	1/4
2R3[]	1/8	3/16
2R4[]	1/8	1/4
2R6[]	1/8	3/8
2R8[]	1/8	1/2
3R4[]	3/16	1/4
3R6[]	3/16	3/8
3R8[]	3/16	1/2
4R2[]	1/4	1/8
4R4[]	1/4	1/4
4R6[]	1/4	3/8
4R8[]	1/4	1/2
4R10[]	1/4	5/8
4R12[]	1/4	3/4
6R4[]	3/8	1/4
6R6[]	3/8	3/8
6R8[]	3/8	1/2
6R10[]	3/8	5/8
6R12[]	3/8	3/4
6R14[]	3/8	7/8
6R16[]	3/8	1
8R4[]	1/2	1/4
8R6[]	1/2	3/8
8R8[]	1/2	1/2
8R10[]	1/2	5/8
8R12[]	1/2	3/4
8R16[]	1/2	1
10R12[]	5/8	3/4
10R14[]	5/8	7/8
10R16[]	5/8	1
12R14[]	3/4	7/8
12R16[]	3/4	1
16R24[]	1	1 1/2
20R24[]	1 1/4	1 1/2
20R32[]	1 1/4	2
24R32[]	1 1/2	2

* [] see page 59-60 for material specifications.

Reducer: R/MM

connects **metric** tube to metric port



Fractional fitting shown

Dimensions — mm

Part Number*	T Tube O.D.	Tx Tube O.D.
3R4[]MM	3	4
3R6[]MM	3	6
3R10[]MM	3	10
4R6[]MM	4	6
4R8[]MM	4	8
4R10[]MM	4	10
6R3[]MM	6	3
6R4[]MM	6	4
6R8[]MM	6	8
6R10[]MM	6	10
6R12[]MM	6	12
6R18[]MM	6	18
8R6[]MM	8	6
8R8[]MM	8	8
8R10[]MM	8	10
8R12[]MM	8	12
8R16[]MM	8	16
10R2[]MM	10	2
10R6[]MM	10	6
10R8[]MM	10	8
10R12[]MM	10	12
10R16[]MM	10	16
10R18[]MM	10	18
10R25[]MM	10	25
12R6[]MM	12	6
12R8[]MM	12	8
12R10[]MM	12	10
12R16[]MM	12	16
12R18[]MM	12	18
12R22[]MM	12	22
12R25[]MM	12	25
14R12[]MM	14	12
15R12[]MM	15	12
16R12[]MM	16	12
18R10[]MM	18	10
18R12[]MM	18	12
18R16[]MM	18	16
18R22[]MM	18	22
18R25[]MM	18	25
25R32[]MM	25	32
30R25[]MM	30	25
32R10[]MM	32	10
32R25[]MM	32	25
38R25[]MM	38	25

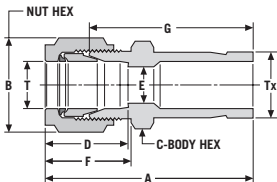

* [] see page 59-60 for material specifications.

Reducing Assemblies Made With GYROLOK® Fittings

Use the GYROLOK® Reducer to reduce the size of an existing fitting, there by providing more flexibility in a variety of installations. It comes with a GYROLOK® fitting on one end and a machined tube stub on the other.

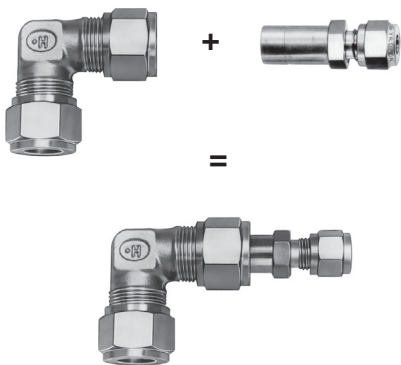

* [] see page 59-60 for material specifications.

Reducer: R/ME

connects metric tube to fractional port

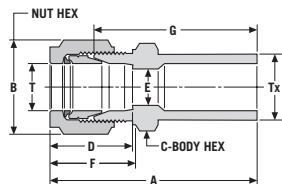
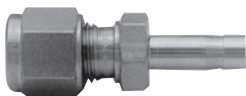

Dimensions — mm

Part Number*	T	Tx
	Tube O.D.	Tube O.D.
3R2[]ME	3	1/8
3R4[]ME	3	1/4
3R6[]ME	3	3/8
4R4[]ME	4	1/4
6R2[]ME	6	1/8
6R4[]ME	6	1/4
6R6[]ME	6	3/8
6R8[]ME	6	1/2
6R10[]ME	6	5/8
8R6[]ME	8	3/8
8R8[]ME	8	1/2
8R10[]ME	8	5/8
10R6[]ME	10	3/8
10R8[]ME	10	1/2
10R10[]ME	10	5/8
12R8[]ME	12	1/2
12R12[]ME	12	3/4
18R12[]ME	18	3/4
25R16[]ME	25	1

Reducer: R/EM

connects fractional tube to metric port

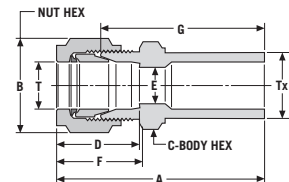

Dimensions — inches

Part Number*	T	Tx
	Tube O.D.	Tube O.D.
1R3[]EM	1/16	3
1R8[]EM	1/16	8
2R6[]EM	1/8	6
4R3[]EM	1/4	3
4R8[]EM	1/4	8
4R10[]EM	1/4	10
4R12[]EM	1/4	12
4R18[]EM	1/4	18

* [] see page 59-60 for material specifications.

Bulkhead Adapter: BA

connects **fractional** tube to fractional port

Dimensions — inches

Part Number*	T Tube O.D.
2BA2[]	1/8
3BA3[]	3/16
4BA4[]	1/4
6BA6[]	3/8
8BA8[]	1/2
10BA10[]	5/8
12BA12[]	3/4
16BA16[]	1



Metric fitting shown

Bulkhead Adapter: BA/MM

connects **metric** tube to metric port

Dimensions — mm

Part Number*	T Tube O.D.
3BA3[]MM	3
4BA4[]MM	4
6BA6[]MM	6
8BA8[]MM	8
10BA10[]MM	10
12BA12[]MM	12
14BA14[]MM	14
16BA16[]MM	16
18BA18[]MM	18
22BA22[]MM	22
25BA25[]MM	25

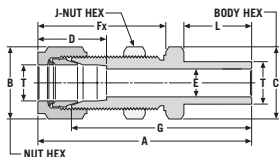

* [] see page 59-60 for material specifications.

Cap: CP caps end of fractional tube



Fractional shown

Dimensions — inches

Part Number*	T Tube O.D.
1CP []	1/16
2CP []	1/8
3CP []	3/16
4CP []	1/4
6CP []	3/8
8CP []	1/2
10CP []	5/8
12CP []	3/4
16CP []	1
20CP []	1 1/4
24CP []	1 1/2
32CP []	2

Tube Cap: CP/MM caps end of metric tube

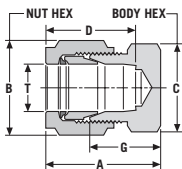

Dimensions — mm

Part Number*	T Tube O.D.
3CP []MM	3
4CP []MM	4
6CP []MM	6
8CP []MM	8
10CP []MM	10
12CP []MM	12
14CP []MM	14
15CP []MM	15
16CP []MM	16
18CP []MM	18
20CP []MM	20
22CP []MM	22
25CP []MM	25
30CP []MM	30
32CP []MM	32
38CP []MM	38

* [] see page 59-60 for material specifications.

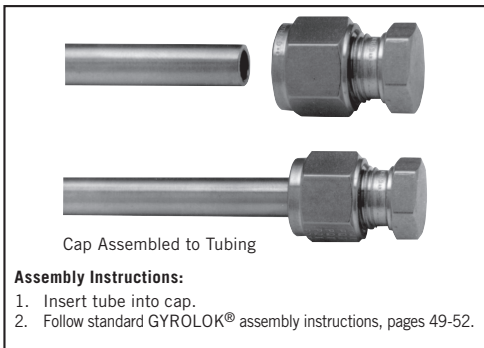

Plug: **P fractional** for GYROLOK® ports

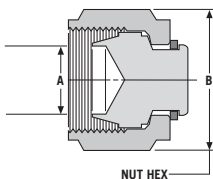

Fractional shown

Dimensions — inches

Part Number*	A Fitting Size	B Hex Size
1P []	1/16	5/16
2P []	1/8	7/16
3P []	3/16	1/2
4P []	1/4	9/16
6P []	3/8	11/16
8P []	1/2	7/8
10P []	5/8	1
12P []	3/4	1 1/8
16P []	1	1 1/2
20P []	1 1/4	1 7/8
24P []	1 1/2	2 1/4
32P []	2	3

* [] see page 59-60 for material specifications.

Plug: P/MM metric for GYROLOK® ports

Dimensions — mm

Part Number*	A Fitting Size	B Hex Size
3P[]MM	3	11.1
4P[]MM	4	12.7
6P[]MM	6	14.3
8P[]MM	8	15.9
10P[]MM	10	19.1
12P[]MM	12	22.2
14P[]MM	14	23.8
15P[]MM	15	23.8
16P[]MM	16	25.4
18P[]MM	18	28.6
20P[]MM	20	31.8
22P[]MM	22	31.8
25P[]MM	25	38.1
30P[]MM	30	50.8
32P[]MM	32	50.8
38P[]MM	38	60.3

Usage Instructions:

1. Remove nut and ferrules from body.
2. Place plug assembly onto GYROLOK® fitting body. Tighten to hand-tight condition.
3. Turn nut with wrench until sharp rise in torque. Then snug tight. (Do not tighten $1\frac{1}{4}$ turns. No ferrules to set).

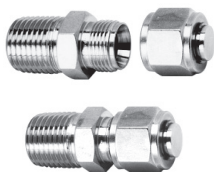

Plug Assembled to GYROLOK® Body

Male Thermocouple Connector: CMT (Fractional)

Dimensions — inches

Part Number*	T	P
	Tube O.D.	Pipe Thd.
1CMT1[]	1/16	1/16
1CMT2[]	1/16	1/8
1CMT4[]	1/16	1/4
2CMT2[]	1/8	1/8
2CMT4[]	1/8	1/4
3CMT2[]	3/16	1/8
3CMT4[]	3/16	1/4
4CMT2[]	1/4	1/8
4CMT4[]	1/4	1/4
4CMT6[]	1/4	3/8
4CMT8[]	1/4	1/2
6CMT4[]	3/8	1/4
6CMT6[]	3/8	3/8
6CMT8[]	3/8	1/2
8CMT8[]	1/2	1/2
12CMT12[]	3/4	3/4
20CMT20[]	1 1/4	1 1/4

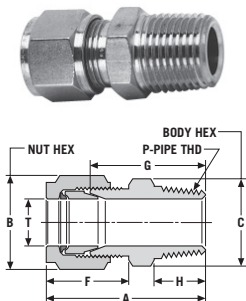

The CMT body does not contain a sizing angle or butt seal. As a result, the thermocouple can be extended beyond the fitting's NPT thread end.

Example: GYROLOK® CMT assembled to thermocouple.

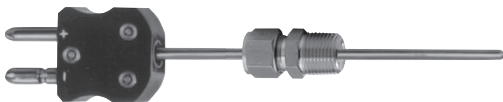

Assembly Instruction:

Because the thermocouple is not bottomed out within the fitting body, follow these simple steps before carrying out GYROLOK® assembly instructions on page 49.

1. Position the length of the thermocouple to extend past the fitting's NPT end.
2. Once correctly positioned, carefully hold thermocouple in place to prevent shifting during assembly

* [] see page 59-60 for material specifications.

Male Thermocouple Connector: CMT/ME, CMT/MC (Metric) Metric Tube with NPT or RT tapered threads

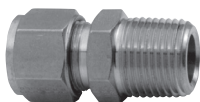

Dimensions — mm

Part Number*		T Tube O.D.	P Pipe Thd.
6CMT2[]ME	6CMT2[]MC	6	1/8
6CMT4[]ME	6CMT4[]MC	6	1/4
8CMT4[]ME	8CMT4[]MC	8	1/4

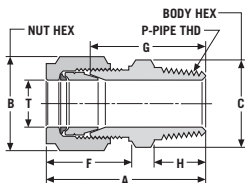

Male Thermocouple Connector: CMT/MA (Metric) Metric Tube with RS parallel threads

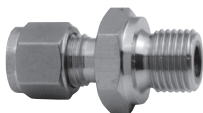

Dimensions — mm

Part Number*	T Tube O.D.	S Straight Thd.
6CMT4[]MA	6	1/4

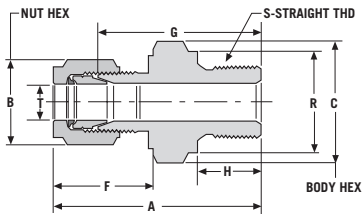

NOTE: RS parallel thread ends are typically used with a gasket having a bonded elastomer seal. RP-type gaskets may also be used.

Heat Exchanger Tee: XT

Dimensions — inches

Part Number*	T Tube O.D.	Tx Tube O.D.
4XT2[]BR4	1/4	1/8
8XT4[]BR4	1/2	1/4
8XT4[]BR8	1/2	1/4

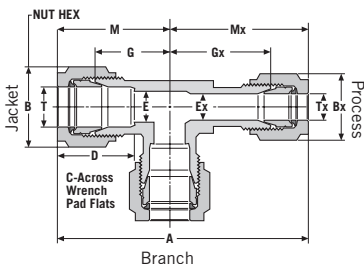

Special Ordering Instructions:

Heat Exchanger Tees are available in other fractional and metric sizes by special order. Ask your HOKE® distributor for price and availability information. Specify "Heat Exchanger Tee" followed by quantity and the desired tube connection sizes.

Example: 8XT4[]BR8

1. Jacket and tubing O.D.
2. Process tubing O.D.
3. Specify material
4. Branch tubing O.D.
5. Metric

Standard Fitting

- 1/2"
1/4"
*
1/2"
—

* [] see page 59-60 for material specifications.

Heat Exchanger Tee Made With GYROLOK® Tube Fittings



Assembly of Tee Union Tees With Full Port Reducer

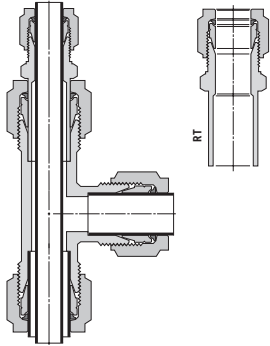

Heat exchanger tees made with GYROLOK® tube fittings can provide additional flexibility as well as reduce costly fitting inventories.

Ordering Instructions

Heat Exchanger Tees can be created with standard union tees and full port reducers to allow process tubing to be inserted into and through the jacket tubing.

To order a full port reducer, add the letter "T" to the core reducer part number.

Example: 8RT12316

Male Adapter: AM (Fractional)

Dimensions — inches

Part Number*	T Tube O.D.	P Male NPT Size
1AM1[]	1/16	1/16
1AM2[]	1/16	1/8
2AM2[]	1/8	1/8
2AM4[]	1/8	1/4
3AM2[]	3/16	1/8
3AM4[]	3/16	1/4
4AM2[]	1/4	1/8
4AM4[]	1/4	1/4
4AM6[]	1/4	3/8
4AM8[]	1/4	1/2
6AM2[]	3/8	1/8
6AM4[]	3/8	1/4
6AM6[]	3/8	3/8
6AM8[]	3/8	1/2
8AM4[]	1/2	1/4
8AM6[]	1/2	3/8
8AM8[]	1/2	1/2
8AM12[]	1/2	3/4
10AM6[]	5/8	3/8
10AM8[]	5/8	1/2
10AM12[]	5/8	3/4
12AM8[]	3/4	1/2
12AM12[]	3/4	3/4
12AM16[]	3/4	1
16AM12[]	1	3/4
16AM16[]	1	1
20AM20[]	1 1/4	1 1/4
24AM24[]	1 1/2	1 1/2
32AM32[]	2	2

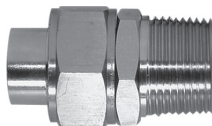
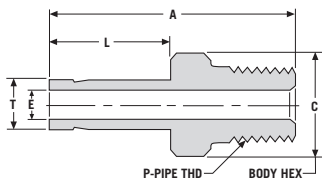
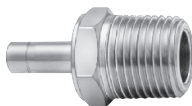

20AM20[] shown

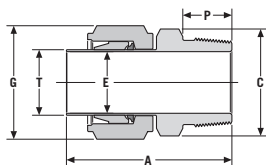

NOTE: Over 1 inch and over 25 mm Male Adapters feature pre-set ferrules. Follow GYROLOK® Reassembly Instructions, pages 49-52.

* [] see page 59-60 for material specifications.

Male Adapter: AM/MC/ME (Metric) with RT Ends

Dimensions — mm

Part Number*		T Tube O.D.	P Pipe Thd.
3AM2[]MC	3AM2[]ME	3	1/8
3AM4[]MC	3AM4[]ME	3	1/4
4AM2[]MC	4AM2[]ME	4	1/8
4AM4[]MC	4AM4[]ME	4	1/4
6AM2[]MC	6AM2[]ME	6	1/8
6AM4[]MC	6AM4[]ME	6	1/4
6AM6[]MC	6AM6[]ME	6	3/8
6AM8[]MC	6AM8[]ME	6	1/2
8AM2[]MC	8AM2[]ME	8	1/8
8AM4[]MC	8AM4[]ME	8	1/4
8AM6[]MC	8AM6[]ME	8	3/8
8AM8[]MC	8AM8[]ME	8	1/2
10AM2[]MC	10AM2[]ME	10	1/8
10AM4[]MC	10AM4[]ME	10	1/4
10AM6[]MC	10AM6[]ME	10	3/8
10AM8[]MC	10AM8[]ME	10	1/2
12AM4[]MC	12AM4[]ME	12	1/4
12AM6[]MC	12AM6[]ME	12	3/8
12AM8[]MC	12AM8[]ME	12	1/2
14AM4[]MC	14AM4[]ME	14	1/4
14AM6[]MC	14AM6[]ME	14	3/8
14AM8[]MC	14AM8[]ME	14	1/2
15AM8[]MC	15AM8[]ME	15	1/2
16AM6[]MC	16AM6[]ME	16	3/8
16AM8[]MC	16AM8[]ME	16	1/2
16AM12[]MC	16AM12[]ME	16	3/4
16AM16[]MC	16AM16[]ME	16	1
18AM6[]MC	18AM6[]ME	18	3/8
18AM8[]MC	18AM8[]ME	18	1/2
18AM12[]MC	18AM12[]ME	18	3/4
20AM8[]MC	20AM8[]ME	20	1/2
20AM12[]MC	20AM12[]ME	20	3/4
22AM8[]MC	22AM8[]ME	22	1/2
22AM12[]MC	22AM12[]ME	22	3/4
25AM8[]MC	25AM8[]ME	25	1/2
25AM12[]MC	25AM12[]ME	25	3/4
25AM16[]MC	25AM16[]ME	25	1

* [] see page 59-60 for material specifications.

Male Adapter: AM/EC (Fractional)

connects **fractional** port to female RT tapered threads

Dimensions — inches

Part Number*	T Tube O.D.	P Pipe Thd.
4AM2[]EC	1/4	1/8
4AM4[]EC	1/4	1/4
6AM4[]EC	3/8	1/4
6AM6[]EC	3/8	3/8
6AM8[]EC	3/8	1/2
8AM8[]EC	1/2	1/2

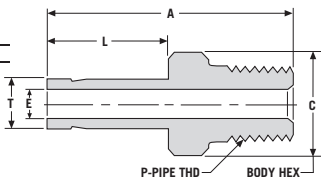

Male Adapter: AM/EA

connects **fractional** port to female RS parallel threads

Dimensions — inches

Part Number*	T Tube O.D.	S Thd. Size
4AM2[]EA	1/4	1/8
4AM4[]EA	1/4	1/4
6AM6[]EA	3/8	3/8
8AM8[]EA	1/2	1/2

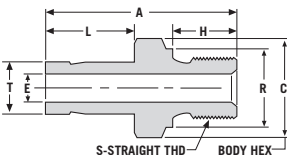

Male Adapter: AM/MB

connects **metric** port to female ISO straight thread

Dimensions — mm

Part Number*	T Tube O.D.	S Thd. Size
6AM4[]MB	6	1/4
12AM8[]MB	12	1/2

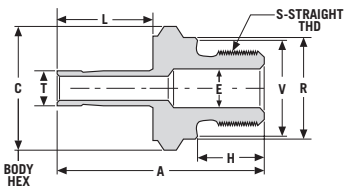
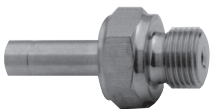

* [] see page 59-60 for material specifications.

O-ring Male Adapter: AOM

connects **fractional** port to female NPT threads

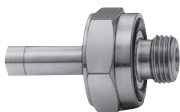

Dimensions — inches

Part Number*	T Tube O.D.	P Pipe Size
1AOM2[]	1/16	1/8
2AOM2[]	1/8	1/8
2AOM4[]	1/8	1/4
3AOM2[]	3/16	1/8
3AOM4[]	3/16	1/4
4AOM2[]	1/4	1/8
4AOM4[]	1/4	1/4
4AOM6[]	1/4	3/8
6AOM2[]	3/8	1/8
6AOM4[]	3/8	1/4

O-ring Male Adapter: AOM/ME

connects **metric** port to female NPT threads

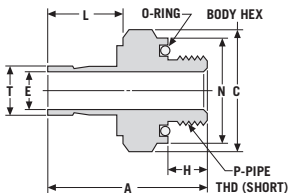

Dimensions — mm

Part Number*	T Tube O.D.	P Pipe Size
6AOM2[]ME	6	1/8
6AOM4[]ME	6	1/4
10AOM4[]ME	10	1/4
10AOM6[]ME	10	3/8
12AOM6[]ME	12	3/8
12AOM8[]ME	12	1/2

O-ring Straight Adapter: AOS

connects **fractional** port to female O-ring straight thread



Dimensions — inches

Part Number*	T Tube O.D.	S Thd. Size
1AOS[]	1/16	5/16-24
2AOS[]	1/8	5/16-24
3AOS[]	3/16	3/8-24
4AOS[]	1/4	7/16-20
6AOS[]	3/8	9/16-18
8AOS[]	1/2	3/4-16

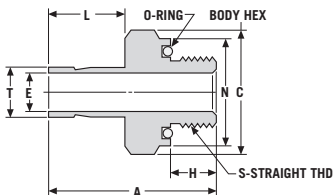

* [] see page 59-60 for material specifications.

Male SAE Adapter: AMS

connects **fractional** port to SAE/MS straight thread boss

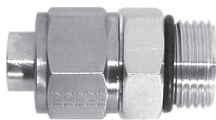
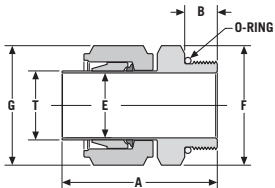

Dimensions — inches

Part Number	T	
	Tube O.D.	S
20AMS20316	1 1/4	1 5/8-12
24AMS24316	1 1/2	1 7/8-12
32AMS32316	2	2 1/2-12

Female Adapter: AF

connects **fractional** port to male NPT thread

Dimensions — inches

Part Number*	T Tube O.D.	P Pipe Size
2AF2[]	1/8	1/8
2AF4[]	1/8	1/4
3AF2[]	3/16	1/8
3AF4[]	3/16	1/4
4AF2[]	1/4	1/8
4AF4[]	1/4	1/4
4AF6[]	1/4	3/8
4AF8[]	1/4	1/2
6AF2[]	3/8	1/8
6AF4[]	3/8	1/4
6AF6[]	3/8	3/8
6AF8[]	3/8	1/2
8AF4[]	1/2	1/4
8AF6[]	1/2	3/8
8AF8[]	1/2	1/2
10AF6[]	5/8	3/8
10AF8[]	5/8	1/2
10AF12[]	5/8	3/4
12AF8[]	3/4	1/2
12AF12[]	3/4	3/4
12AF16[]	3/4	1
16AF8[]	1	1/2
16AF12[]	1	3/4
16AF16[]	1	1
20AF20[]	1 1/4	1 1/4
24AF24[]	1 1/2	1 1/2
32AF32[]	2	2

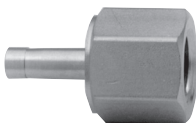

Metric fitting shown

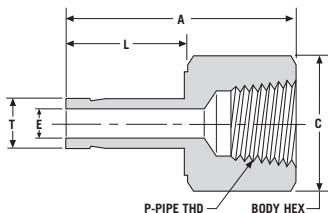

* [] see page 59-60 for material specifications.

Female Adapter: AF/ME

connects **metric** port to male NPT thread

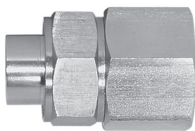

20AF20[] shown

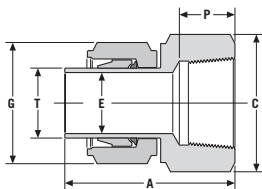

NOTE: Over 1 inch and over 25 mm Female Adapters feature pre-set ferrules. Use the GYROLOK® remake instructions, page 49.

Dimensions — mm

Part Number*	T Tube O.D.	P Pipe Size
3AF2[]ME	3	1/8
3AF4[]ME	3	1/4
6AF2[]ME	6	1/8
6AF4[]ME	6	1/4
6AF6[]ME	6	3/8
6AF8[]ME	6	1/2
8AF2[]ME	8	1/8
8AF4[]ME	8	1/4
8AF6[]ME	8	3/8
8AF8[]ME	8	1/2
10AF2[]ME	10	1/8
10AF4[]ME	10	1/4
10AF6[]ME	10	3/8
10AF8[]ME	10	1/2
12AF4[]ME	12	1/4
12AF6[]ME	12	3/8
12AF8[]ME	12	1/2
12AF12[]ME	12	3/4
14AF4[]ME	14	1/4
14AF8[]ME	14	1/2
15AF8[]ME	15	1/2
16AF6[]ME	16	3/8
16AF8[]ME	16	1/2
16AF12[]ME	16	3/4
18AF6[]ME	18	3/8
18AF8[]ME	18	1/2
18AF12[]ME	18	3/4
20AF8[]ME	20	1/2
20AF12[]ME	20	3/4
22AF8[]ME	22	1/2
22AF12[]ME	22	3/4
25AF8[]ME	25	1/2
25AF12[]ME	25	3/4
25AF16[]ME	25	1

Female Adapter: AF/EZ

connects **fractional** port to male RG parallel threads (gauge)

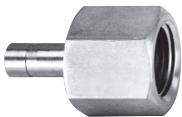

Dimensions — inches

Part Number*	T Tube O.D.	S Thd. Size
4AF4[]EZ	1/4	1/4
4AF8[]EZ	1/4	1/2
8AF4[]EZ	1/2	1/4
8AF8[]EZ	1/2	1/2

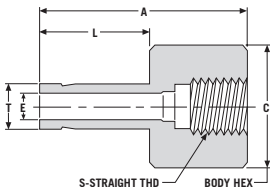

* [] see page 59-60 for material specifications.

Union Tee Plus Adapter Assemblies Help Eliminate Costly Inventory

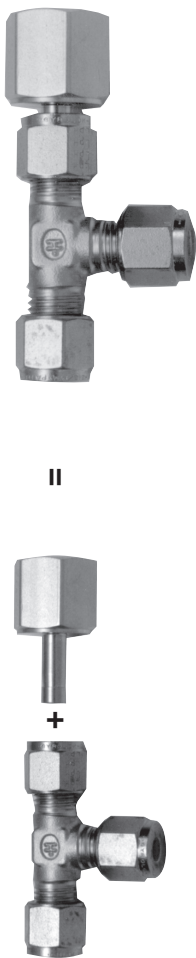

The GYROLOK® Female Adapter converts a male pipe thread to a tube stub end so that any GYROLOK® tube fitting of proper size can be connected. It comes with a female pipe thread on one end and a machined tube stub on the other. By using adapters with union tees, you'll need fewer male or female branch tees and run tees.

Female Adapter: AF/MZ

connects **metric** port to male RG parallel threads (gauge)

Dimensions — mm

Part Number*	T Tube O.D.	S Straight Thd.
6AF4[]MZ	6	1/4
6AF8[]MZ	6	1/2
8AF4[]MZ	8	1/4
8AF8[]MZ	8	1/2
10AF4[]MZ	10	1/4
10AF8[]MZ	10	1/2
12AF4[]MZ	12	1/4
12AF8[]MZ	12	1/2
14AF8[]MZ	14	1/2
16AF8[]MZ	16	1/2
18AF8[]MZ	18	1/2
22AF8[]MZ	22	1/2
25AF8[]MZ	25	1/2

NOTE: RG female thread ends require a gasket inserted into the bottom of the thread. The male end, when assembled, exerts pressure on the gasket creating a seal.

Female Adapter: AF/EC

connects **fractional** port to male RT tapered threads

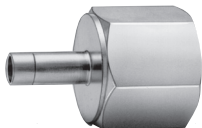

Metric fitting shown

Dimensions — inches

Part Number*	T Tube O.D.	S Thd. Size
4AF2[]EC	1/4	1/8
4AF4[]EC	1/4	1/4
6AF6[]EC	3/8	3/8
8AF8[]EC	1/2	1/2

Female Adapter: AF/MC

connects **metric** port to male RT tapered threads

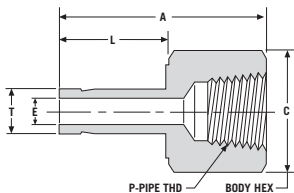

Dimensions — mm

Part Number*	T Tube O.D.	P Pipe Thd.
3AF2[]JMC	3	1/8
3AF4[]JMC	3	1/4
6AF2[]JMC	6	1/8
6AF4[]JMC	6	1/4
6AF6[]JMC	6	3/8
6AF8[]JMC	6	1/2
8AF2[]JMC	8	1/8
8AF4[]JMC	8	1/4
8AF6[]JMC	8	3/8
8AF8[]JMC	8	1/2
10AF2[]JMC	10	1/8
10AF4[]JMC	10	1/4
10AF6[]JMC	10	3/8
10AF8[]JMC	10	1/2
12AF4[]JMC	12	1/4
12AF6[]JMC	12	3/8
12AF8[]JMC	12	1/2
12AF12[]JMC	12	3/4

* [] see page 59-60 for material specifications.

Front Ferrule: FF (Fractional)

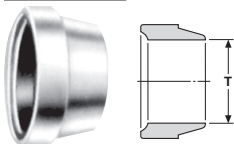

Dimensions — inches

Part Number*	T Tube O.D.
1FF[]	1/16
2FF[]	1/8
3FF[]	3/16
4FF[]	¼
6FF[]	3/8
8FF[]	½
10FF[]	5/8
12FF[]	¾
14FF[]	7/8
16FF[]	1
20FF[]	1¼
24FF[]	1½
32FF[]	2

Front Ferrule: FF/MM (Metric)

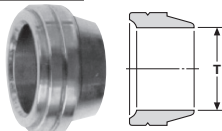

Dimensions — mm

Part Number*	T Tube O.D.
3FF[]MM	3
4FF[]MM	4
6FF[]MM	6
8FF[]MM	8
10FF[]MM	10
12FF[]MM	12
14FF[]MM	14
15FF[]MM	15
16FF[]MM	16
18FF[]MM	18
20FF[]MM	20
22FF[]MM	22
25FF[]MM	25
30FF[]MM	30
32FF[]MM	32
38FF[]MM	38

Rear Ferrule: FR (Fractional)

Dimensions — inches

Part Number*	T Tube O.D.
1FR[]	1/16
2FR[]	1/8
3FR[]	3/16
4FR[]	¼
6FR[]	3/8
8FR[]	½
10FR[]	5/8
12FR[]	¾
14FR[]	7/8
16FR[]	1
20FR[]	1¼
24FR[]	1½
32FR[]	2

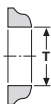

Rear Ferrule: FR/MM (Metric)

Dimensions — mm

Part Number*	T Tube O.D.
3FR[]MM	3
4FR[]MM	4
6FR[]MM	6
8FR[]MM	8
10FR[]MM	10
12FR[]MM	12
14FR[]MM	14
15FR[]MM	15
16FR[]MM	16
18FR[]MM	18
20FR[]MM	20
22FR[]MM	22
25FR[]MM	25
30FR[]MM	30
32FR[]MM	32
38FR[]MM	38

Nylon front and rear ferrules are available in both fractional and metric.

Note: Stainless steel front ferrules larger than 1" and 25mm are PFA coated.

* [] see page 59-60 for material specifications.

Nut: N (Fractional)

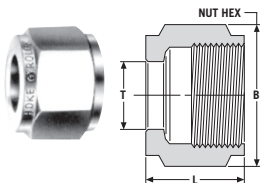

Dimensions — inches

Part Number*	T Tube O.D.
1N []	1/16
2N []	1/8
3N []	3/16
4N []	1/4
6N []	3/8
8N []	1/2
10N []	5/8
12N []	3/4
14N []	7/8
16N []	1
20N []	1 1/4
24N []	1 1/2
32N []	2

Nut: N/MM (Metric)

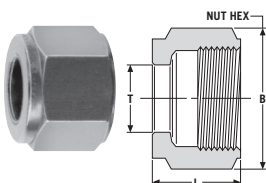

Dimensions — mm

Part Number*	T Tube O.D.
3N []MM	3
4N []MM	4
6N []MM	6
8N []MM	8
10N []MM	10
12N []MM	12
14N []MM	14
15N []MM	15
16N []MM	16
18N []MM	18
20N []MM	20
22N []MM	22
25N []MM	25
30N []MM	30
32N []MM	32
38N []MM	38

Bulkhead Nut: BN (Fractional)

Dimensions — inches

Part Number*	L	J
1BN []	1/8	3/8
2BN []	7/32	1/2
3BN []	7/32	9/16
4BN []	1/4	5/8
6BN []	17/64	3/4
8BN []	5/16	15/16
10BN []	23/64	11/16
12BN []	13/32	13/16
14BN []	13/32	15/16
16BN []	13/32	19/16
24BN []	1/2	2 1/4
32BN []	1/2	2 3/4

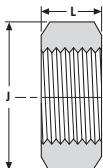

Bulkhead Nut: BN/MM (Metric)

Dimensions — mm

Part Number*	Fitting Size
2BN []	3
3BN []	4
4BN []	6
8BN []MM	8
10BN []MM	10
8BN []	12
14BN []MM	14 or 15
10BN []	16
12BN []	18
14BN []	20 or 22
16BN []	25

* [] see page 59-60 for material specifications.

Knurled Nut: KN (Fractional)

Dimensions — inches	
Part Number*	T Tube O.D.
1KN[]	1/16
2KN[]	1/8
3KN[]	3/16
4KN[]	1/4
6KN[]	3/8
8KN[]	1/2
10KN[]	5/8
12KN[]	3/4
14KN[]	7/8
16KN[]	1

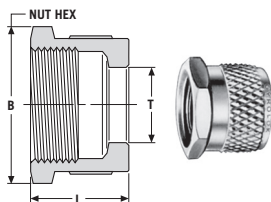

GYROLOK® Fittings are available with knurled nuts and nylon ferrules for use with polyethylene tubing. Hand-tightening allows for quick, easy assembly and disassembly, while providing a leak-tight seal, ideally suited for laboratory hookups. Use such fittings with glass and other hard wall tubing materials.

To order, simply add **KNN** to the basic part number.

Example: 4CM4 with a knurled nut and nylon ferrules would be **4CM4KNN**.

Screen: SCRN

Dimensions — inches	
Part Number*	GYROLOK® End Size
4SCRN316	1/4
6SCRN316	3/8



Use to prevent insects from entering open vent lines.

Usage Instructions:

1. Substitute screen for rear ferrule in an open GYROLOK®-ended line. (No tubing connected.)
2. Finger-tighten nut.

* [] see page 59-60 for material specifications.

GYROLOK® Calibration Fittings

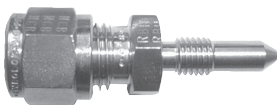

GYROLOK® Calibration Fittings save time and money by reducing the time required to calibrate differential pressure transmitters. HOKE's calibration fittings, constructed of 316 Stainless Steel, combine a straight thread and conical metal-to-metal sealing surface on one end with a 1/4" GYROLOK® tube fitting on the other. This design allows the technician to easily calibrate the transmitter – in place – without removing the pipe plug/bleed port tap assemblies. No TFE tape is required. GYROLOK®'s exclusive Controlled Ferrule Drive increases value – extending cycle life.

Features

Straight Thread/Metal-to-Metal Sealing:

Controlled Ferrule Drive:

Butt Seal:

Sizing Angle:

Nut and Ferrule Safety Changer:

Benefits

- Ease of installation
- Greatly extends remake life
- Protects tubing from overstressing
- Maximizes seal integrity and user safety
- Reduces tube sticking
- Safe, simple component replacement

Dimensions (Fractional)

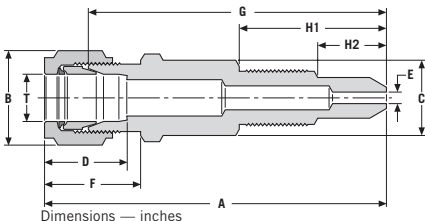

Part Number	T Tube O.D.	Straight Thread
CM005[]	1/4	1/4-28
CM009[]	1/4	5/16-24

CM005—For use with Honeywell transmitters

CM009—For use with Rosemount or Foxboro transmitters

Lapped Flange Connector

Lapped Flange Connector: CLF (Fractional)

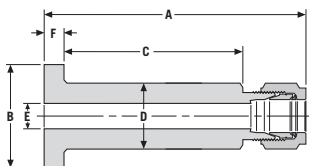

Dimensions — inches

Part Number	T Tube O.D.
4CLFA[]	1/4
4CLFB[]	1/4
6CLFA[]	3/8
6CLFB[]	3/8
8CLFA[]	1/2
8CLFB[]	1/2

Lapped Flange Connector: CLF/MM (Metric)

Dimensions — mm

Part Number	T Tube O.D.
10CLFA[]MM	10
10CLFB[]MM	10

Flange Seal A



Smooth

Flange Seal B



Serrated / Concentric

The Lapped Flange Connector is used to allow safe and easy connections between process lines and instruments. The basic, one-piece unit consists of a GYROLOK® tube connection end and a 1/2" lap joint pipe flange. The flange end is dimensioned to meet "ANSI 2500" flange specifications. Available in "Smooth" or "Serrated/Concentric" seal faces, and in 316 Stainless Steel or MONEL®.

GYROLOK® Dielectric Tube Fittings

The GYROLOK® Dielectric Tube Fittings are for use in applications where electrical current flowing through a pipe or tube line must be interrupted to protect vital instrumentation and metering equipment.



Features	Benefits
Thermoplastic Insulators with: <ul style="list-style-type: none">• Resistance in excess of 10^8 ohms at 70° F (21° C) and 50% relative humidity.• Resistance in excess of 10^6 ohms at 100° F (38° C) and 90% relative humidity.	<ul style="list-style-type: none">• Maximum safety and protection to critical monitoring station instrumentation.
Metal components made of 316 Stainless Steel:	<ul style="list-style-type: none">• Long component life in rugged environment.
Appropriate orifice for fitting size (e.g. .422" orifice in 1/2" fitting):	<ul style="list-style-type: none">• Maximum flow capability provided by all sizes of GYROLOK® Dielectric tube fittings.
GYROLOK® tube fitting ends:	<ul style="list-style-type: none">• The unique value and performance offered by GYROLOK®.

Technical Data

Body Construction Materials:	<ul style="list-style-type: none">• 316 Stainless Steel
Insulator:	<ul style="list-style-type: none">• Molded Thermoplastic
O-ring Material:	<ul style="list-style-type: none">• 90 Durometer Viton
Back-up Washer:	<ul style="list-style-type: none">• Virgin TFE
Electrical Resistance of Insulators:	<ul style="list-style-type: none">• $7.0 \times 10^8 \Omega$ @ 10 Volts DC @ 70° F and 50% relative humidity• $1.0 \times 10^6 \Omega$ @ 10 Volts DC @ 100° F and 90% relative humidity
Pressure Rating:	<ul style="list-style-type: none">• 4000 PSIG @ 70° F (27,580kPa @ 21° C)
Temperature Rating:	<ul style="list-style-type: none">• -40° F to +200° F (-40° C to +93° C)

Design

The Dielectric Tube Fitting must perform three primary functions:

1. Electrical insulation
2. Reliable fluid containment
3. Appropriate flow for line size

In the HOKE® design, the insulation function is performed by thermoplastic insulators which provide performance unequalled by any similar product.

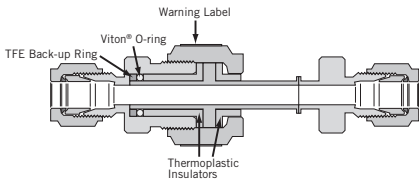

A Viton O-ring and TFE back up ring provide the containment function within the fitting. GYROLOK®'s 2-ferrule system provides sealing with the impulse line tubing.

Appropriate flow for line size is achieved by providing the appropriate inside diameter for tubing size. See "E" dimensions in Dimensional Table.

WARNING: A "NO WRENCHING" label is placed on the hex of the nut in the insulation sections. Do not disconnect at this point. Instructions are provided with every HOKE® Dielectric fitting.

Dielectric Unions: DU

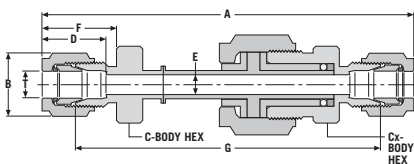

Dimensions — inches

Part No.	T Tube O.D.
4DU316	1/4
6DU316	3/8
8DU316	1/2

Dielectric Male Connectors: DCM

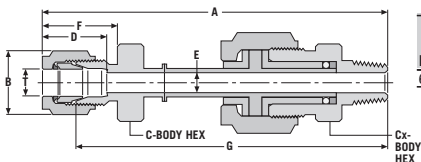

Dimensions — inches

Part No.	T Tube O.D.
6DCM4316	3/8

Application

Commonly used in the Natural Gas Transmission industry, the Dielectric Fitting will prevent current flow resulting from Impressed Current Cathodic Protection Systems, static electricity or even lightning strikes, from reaching sensitive monitoring station equipment.

Impressed Current Cathodic Protection Systems involve the application of a low voltage, low amperage direct current to a pipeline and eventual transfer of corrosive effects to a typically underground anode bed.

If the current flow is not interrupted before reaching the monitoring station critical equipment could be damaged or rendered inaccurate.

By installing GYROLOK® Dielectric Tube Fitting on impulse lines between the pipeline and the monitoring station, current flow is interrupted while full fluid flow is permitted.

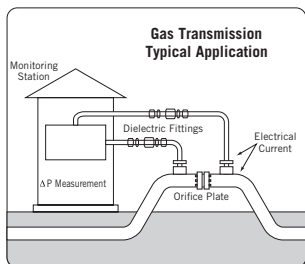

HOKE® Chromatography Fittings

GYROLOK® tube fittings for use in gas or liquid chromatography applications are available in a variety of user-required configurations. HOKE's Chromatography Fittings feature low dead volumes, male nut designs, as well as configurations utilizing either press-fit or drop-in frits. For user convenience, both frit versions are available in a number of micron sizes. By combining the needs of the Chromatography Fitting with key GYROLOK® features, such as controlled ferrule drive, the HOKE® Chromatography Fitting offers capabilities and performance that are unmatched in the industry.



Features

Low Dead Volume:

Press-fit or Drop-in Frits:

Conical Diffusion Angle:

Male Nut Configuration:

Fritless Configurations:

Controlled Ferrule Drive:

Interchangeability:

Benefits

- Accurate analysis and measurement
- Filter elements can be ordered factory installed (press-fit) or for field installation (drop-in)
- 4 micron sizes are offered as standard, other sizes can be provided
- Perform final filtering function for low volume fluids
- Press-fit frit design reduces internal volume
- Assures fluid contact over a greater surface, extending frit life while reducing unfiltered volume
- Reduced internal volume
- For use with G.C. columns or L.C.'s with screens
- Long product life with outstanding remakeability
- Fittings are interchangeable with those of certain other manufacturers (consult factory)

Pressure Ratings

GYROLOK® Chromatography fittings are rated for working pressures higher than the tubing recommended for use. Refer to HOKE's Tubing Data Charts for specific information.

Temperature Ratings

316 Stainless Steel: -325° F to +800° F (-200° C to +425° C)

Note: Intermittent use to 1200° F is possible, however prolonged exposure to temperatures over 800° F is not recommended.

How to Order Dielectric Fittings

2	F	U	M	P	1	316
Tube O.D. in 1/16 of an inch; 2=2/16"=1/8"	Nut Type M = male F = female size 2 nut is female	Fitting Type U = union RU = reducing union CM = male connector	Nut Type M = male F = female only used if different nut type is used	Press-Fit Frit size P = .5 micron R = 2 micron T = 5 micron V = 10 micron	Tube Size in 1/16's of an inch	Material 316 stainless steel

Dimension Tables

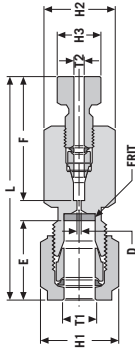

Drop-In Frit

Dimensions — inches

Part No.	Column O.D.
4FRIT * 1316	1/4
6FRIT * 1316	3/8
8FRIT * 1316	1/2
16FRIT * 1316	1

* Frit designator in microns:

E=2.0, G=5.0, I=10.

Assign appropriate letter code for desired size.

Column End Fitting
(for use with drop-in frit)

Dimensions — inches

Part No.	T1 x T2 Tube Sizes
4FUM1316	1/4 x 1/16
6FUM1316	3/8 x 1/16
8FUM1316	1/2 x 1/16
16FUM1316	1 x 1/16

Column End Fitting (with press-fit frit)

Dimensions — inches

Part No.	T1 x T2 Tube Sizes
2FUM[*]1316	1/8 X 1/16
4FUM[*]1316	1/4 X 1/16
6FUM[*]1316	3/8 X 1/16

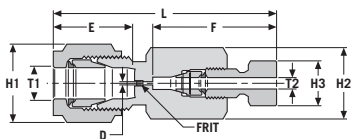

*Frit designator in microns: P=0.5, R=2.0, T=5.0, V=10. Assign letter code to complete part number.

Union (with press-fit frit)

Dimensions — inches

Part No.	T1 x T2 Tube Sizes
2FU[*]1316	1/8 X 1/16
4FU[*]1316	1/4 X 1/16
6FU[*]1316	3/8 X 1/16

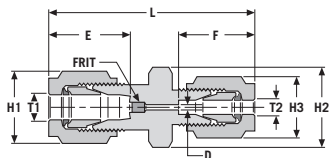

*Frit designator in microns: P=0.5, R=2.0, T=5.0, V=10. Assign letter code to complete part number.

Column End Fitting

Dimensions — inches

Part No.	T1 x T2 Tube Sizes
2FRUM1316	1/8 X 1/16
4FRUM1316	1/4 X 1/16
6FRUM1316	3/8 X 1/16

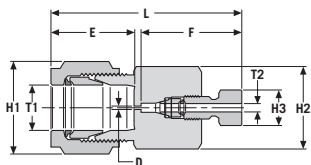

Reducing Union

Dimensions — inches

Part No.	T1 x T2 Tube Sizes
2FRU1316	1/8 X 1/16
4FRU1316	1/4 X 1/16
6FRU1316	3/8 X 1/16

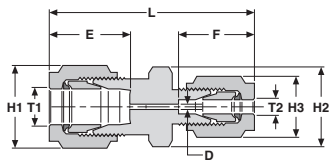

Reducing Union (male nut)

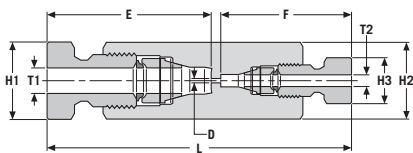

Dimensions — inches

T1 x T2	
Part No.	Tube Sizes
2MRU1316	1/8 X 1/16

Union (male nut)

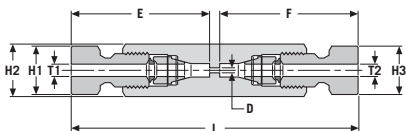

Dimensions — inches

T1 x T2	
Part No.	Tube Sizes
1MU316	1/16 X 1/16
2MU316	1/8 X 1/8

Male Connector (male nut)

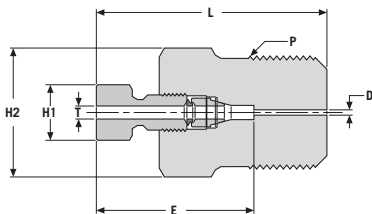

Dimensions — inches

T	
Part No.	Tube Size
1MCM1316	1/16
1MCM2316	1/16
1MCM4316	1/16

Note: All dimensions are for reference only.



The Small Bore Instrumentation Specialists



We specialize in small bore instrumentation products up to 2" that deliver benchmark performance quality & safety; provide the broadest array of superior alloy offerings in the market; decades of proven success in a wide range of industries; a roster of "who's who" customers & projects globally; original "Best Solution" engineering & designs; and are focused on continuous improvement in all aspects of our business.

Proudly Distributed By:



**PRIMINOX
OVERSEAS**



Office No 401, 4th Flr, B Wing, Krishvi Escape,
Behind Vinay Health Home, Sitaram Potdar Marg,
Fanas Wadi, Bhuleshwar, Mumbai - 400002.



+91-22-23853445 | +91-22-67437558



+91-9930544098 | +91-9987462547